

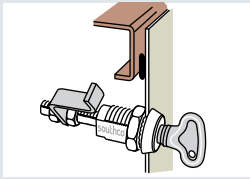

E3 VISE ACTION® Compression Latch

Overview



First 90° turn:
Cam rotates behind frame

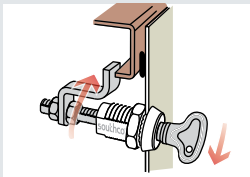

The door is now **latched**
against opening

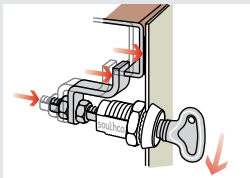

Then as you complete the
half-turn motion, the shaft
and cam compress to pull the
door snugly against the frame
or gasket into the
locked position

Versatility and simplicity in action

Every *SOUTHCO*® *VISE ACTION*® Series latch solution starts with the single-turn latching and compressing action that is built into each model. At the heart of it all is our *VISE ACTION*® design that has proven itself in millions of installations.

Product features

- Suitable for a wide range of load configurations
- Excellent corrosion resistance
- Durable and reliable operation
- Multiple size, material and access configurations
- Compression achieved with minimal manual torque
- Suitable for NEMA4 / IP65 applications

➤ Match material and finish options for style and functionality requirements

Variety of materials and finishes to complement your application.

Die-cast zinc latch bodies standard finishes:



Chrome plated



Black powder coated



Silver powder coated

Stainless steel latch bodies are made by metal injection molding or precise machining.

➤ Select one of these four housing styles to fit your access requirements

A series of basic housing styles of the *VISE ACTION*® compression latch have been developed to meet specific door configuration and mounting requirements - for depth, thickness, strength, grip dimension, and surface protrusion.

- Right and left hand actuation
- Optional pre-assembled cam for quick installation
- Wide choice of accessories

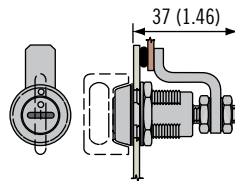

Small

- Optimum compression for use in confined space applications

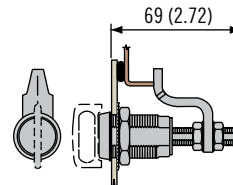

Large

- Largest choice of head styles
- Max. grip range in door to frame spacing
- Minimal protrusion style available

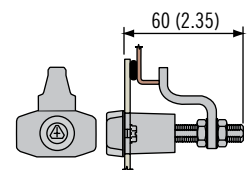

3-Hole Mount

- Simplified round-hole mounting
- Suitable for thick, soft or weak panels



➔ Choose from a wide range of head styles to fit your application and industry requirements

- ➔ Convenient hand operated knob or T-handle styles for easy repetitive access
- ➔ Tool operated for restricted access, flush mount or low profile clearances, and industry specific standards or requirements
- ➔ Key operated for added security

Small single hole door preparation

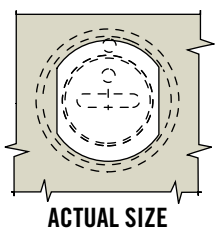

3-Hole body door preparation

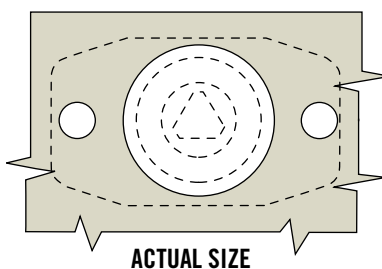
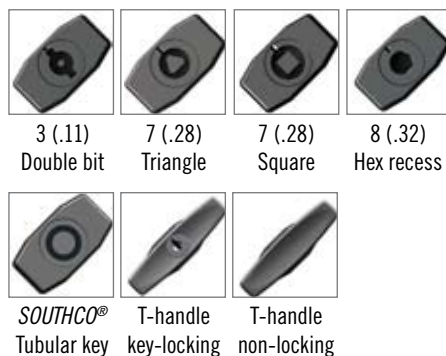

Large single hole body door preparation

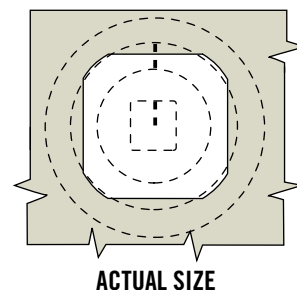

➔ Determine your grip options for a perfect fit

Grip dimension is an important consideration in compression latch applications involving gaskets for environmental or RFI sealing.

For gasketed doors:

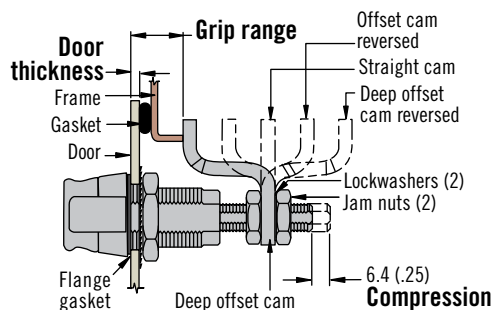
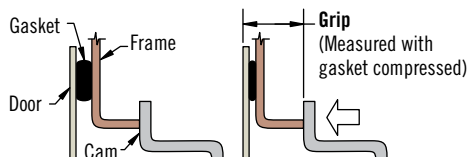

Adjustable cam designs

- Maximum flexibility in tolerance or gasket compression
- Cam choice to suit a broad range of grip dimensions

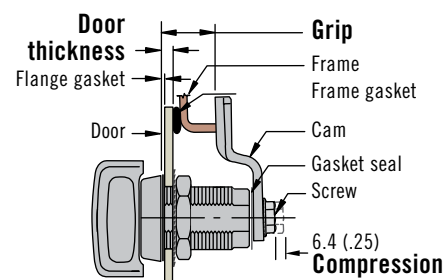

Fixed cam designs

- Precise fit and minimum internal protrusion
- Wide cam selection for accurate grip dimension



E3 VISE ACTION® Compression Latch

Large · Machined stainless steel housing · Tool operated · Adjustable grip

- Consistent pre-set compression
- Easy grip adjustment
- Premium finish and corrosion resistance

Material and Finish

Stainless steel (304 and 316 machined)

Performance Details

Max. static load: 600 N (136 lbf)

Sealing Notes

NEMA 4 and IP65 achieved using gasket supplied

Keys and Accessories

See pages 58 - 61

Installation Notes

Caution: Position cam so latching function can be achieved comfortably by hand.
Recommended tightening torque for the mounting nut is 20 N·m (176 in·lbf).

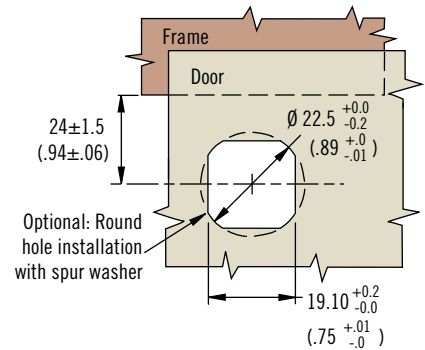
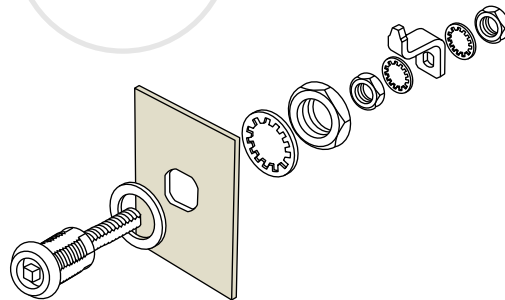
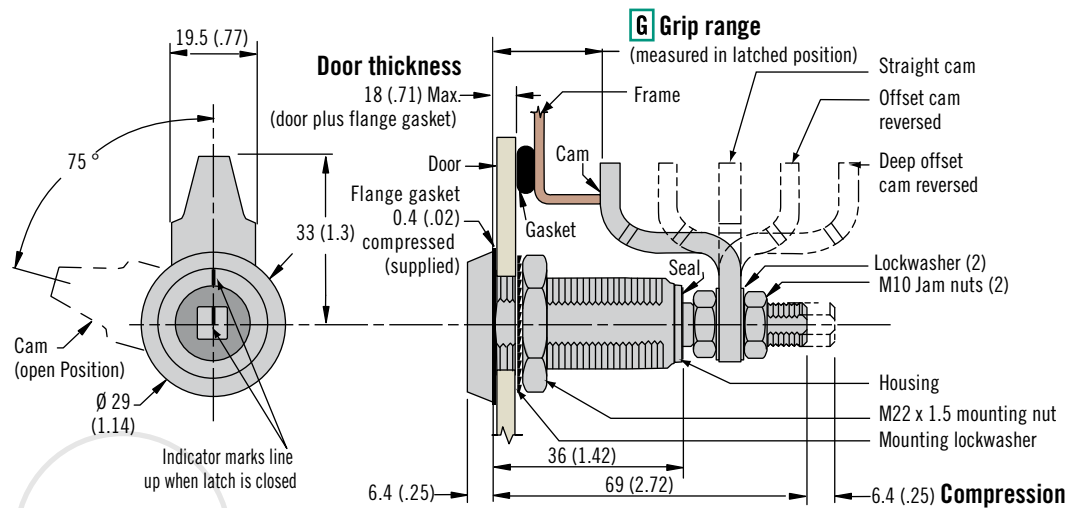

H Head Styles

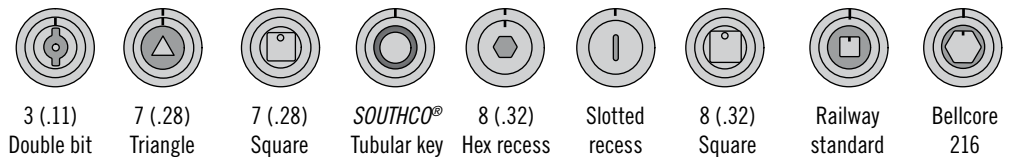

Part Number Selection

- H** Head style
- 2 3 (.11) Double bit
 - 3 7 (.28) Triangle
 - 4 7 (.28) Square
 - 5 SOUTHCO® Tubular key
 - 6 8 (.32) Hex recess
 - 9 Slotted recess
 - 10 8 (.32) Square
 - 11 Railway standard
 - 15 Bellcore 216

G Grip	Min.	Max.	Cam Type
1	16.4 (.64)	32.2 (1.26)	Deep offset cam, forward
	71.3 (2.80)	81.2 (3.19)	Deep offset cam, reversed
2	30.4 (1.19)	46.1 (1.81)	Offset cam, forward
	57.6 (2.26)	73.3 (2.88)	Offset cam, reversed
3	43.9 (1.72)	59.6 (2.34)	Straight cam

E3 - 1 H - G 0

E3 VISE ACTION® Compression Latch

Large · Machined stainless steel housing · Tool operated · Fixed grip

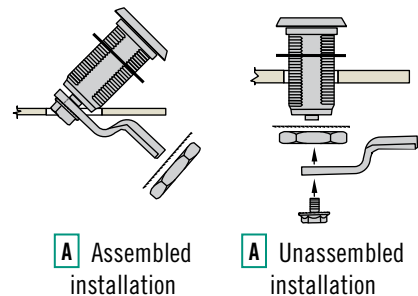
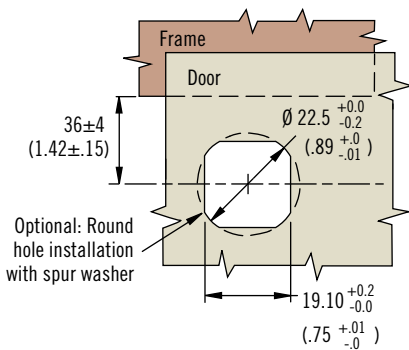
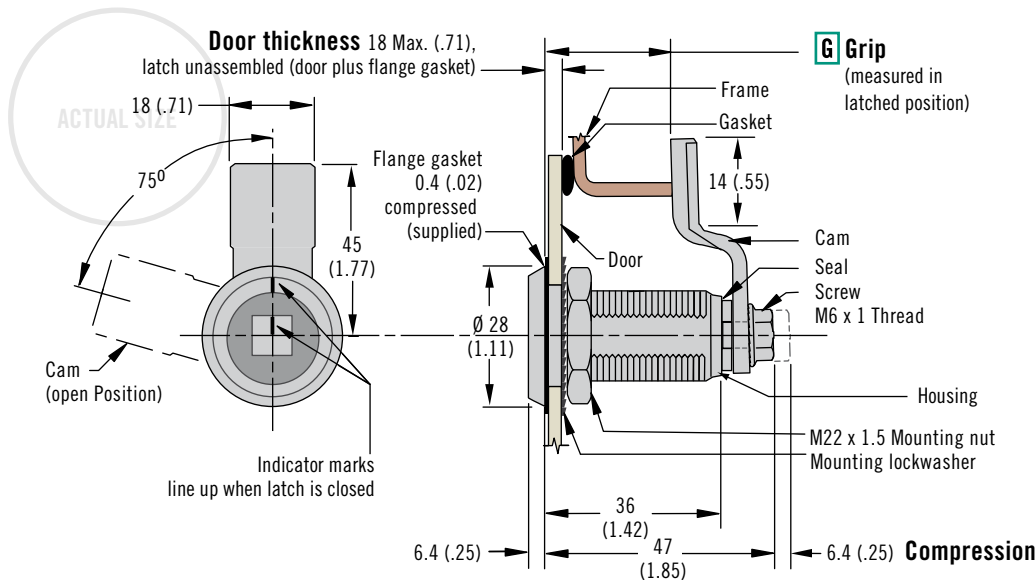

- Consistent pre-set compression
- Premium finish and corrosion resistance
- Reduced internal protrusion

Material and Finish

Stainless steel (304 and 316 machined)

Performance Details

Max. static load: 450 N (102 lbf)

Sealing Notes

NEMA 4 and IP65 achieved using gasket supplied

Keys and Accessories

See pages 58 - 61

Installation Notes

Recommended tightening torque for the mounting nut is 20 N·m (176 in·lbf), and for the mounting screw is 10 N·m (88 in·lbf)

- H** Head style ←
- 2 3 (.11) Double bit
 - 3 7 (.28) Triangle
 - 4 7 (.28) Square
 - 5 SOUTHCO® Tubular key
 - 6 8 (.32) Hex recess
 - 9 Slotted recess
 - 10 8 (.32) Square
 - 11 Railway standard
 - 15 Belcore 216

- A** Assembly status ←
- 10 Assembled
 - 12 Unassembled

E3 - **A** **H** - **G** **O**

Part Number Selection

Select grip from table, if your grip is between two options choose smaller.

G Grip Table ←											
Total Grip	G	Max. Door Thickness for Assembled Latch	Total Grip	G	Max. Door Thickness for Assembled Latch	Total Grip	G	Max. Door Thickness for Assembled Latch	Total Grip	G	Max. Door Thickness for Assembled Latch
20 (.79)	00	1 (.04)	30 (1.18)	05	7 (.28)	40 (1.57)	10	7 (.28)	50 (1.97)	15	7 (.28)
22 (.87)	01	2 (.08)		06		42 (1.65)	11		52 (2.05)	16	
24 (.94)	02	4 (.16)		07		44 (1.73)	12		54 (2.13)	17	
26 (1.02)	03	5 (.20)		08		46 (1.81)	13		56 (2.20)	18	
28 (1.10)	04	6 (.24)		09		48 (1.89)	14		58 (2.28)	19	



E3 VISE ACTION® Compression Latch

Large · Metal injection molding stainless steel housing · Adjustable grip

- Consistent pre-set compression
- Easy grip adjustment
- Tool or hand operated

Material and Finish

Stainless steel 316 and 304

Performance Details

Max. static load: 556 N (125 lbf)

Sealing Notes

NEMA 4 and IP65 achieved using gasket supplied

Installation Notes

Caution: Position cam so latching function can be achieved comfortably by hand. Recommended tightening torque for the mounting nut is 20 N·m (176 in·lbf).

Keys and Accessories

See pages 58 - 61

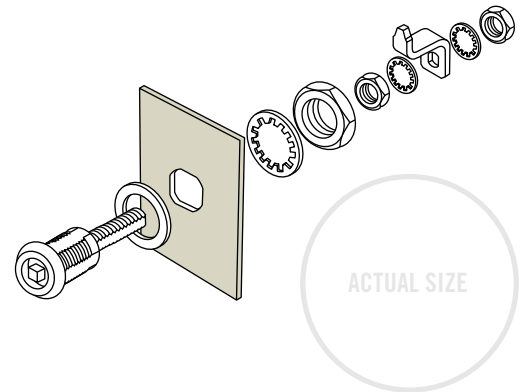
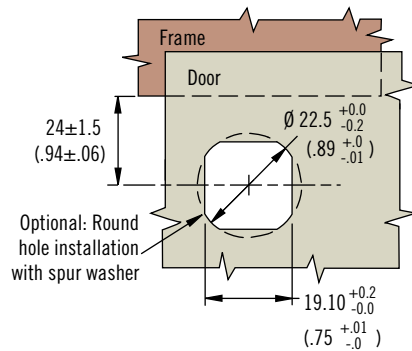
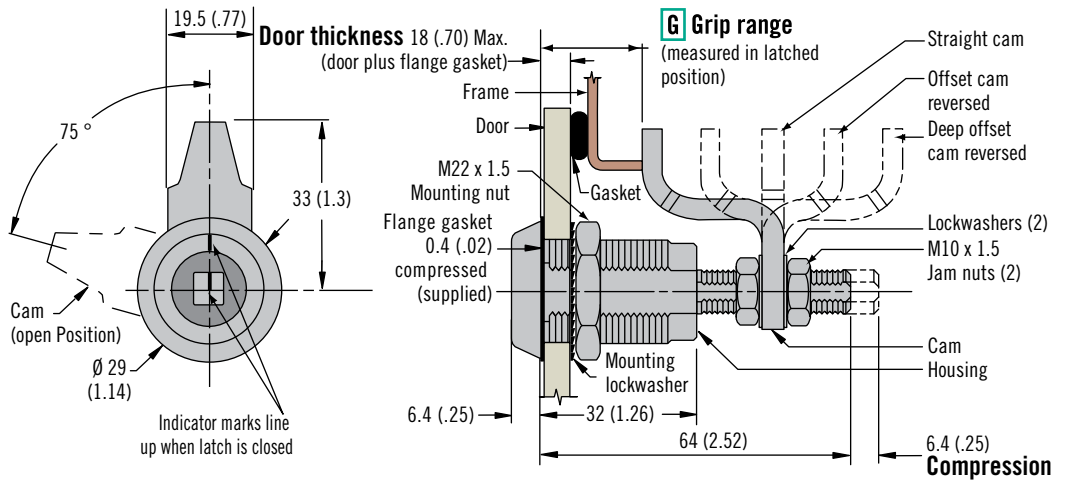

H Head Styles

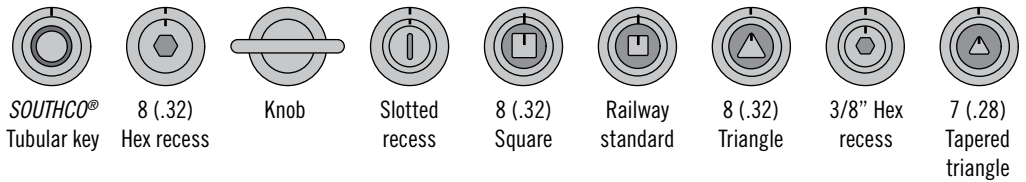

Part Number Selection

- H** Head style
- 5 SOUTHCO® Tubular key
 - 6 8 (.32) Hex recess
 - 7 Knob
 - 9 Slotted recess
 - 10 8 (.32) Square
 - 11 Railway standard
 - 20 8 (.32) Triangle
 - 37 3/8" Hex recess
 - 39 7 (.28) Tapered triangle

G Grip	Min.	Max.	Cam Type
1	11.4 (.45)	27.2 (1.07)	Deep offset cam, forward
	66.3 (2.61)	76.2 (3.00)	Deep offset cam, reversed
2	25.4 (1.00)	41.1 (1.62)	Offset cam, forward
	52.6 (2.07)	68.3 (2.69)	Offset cam, reversed
3	38.9 (1.53)	54.6 (2.15)	Straight cam

E3 - 1 H - G F

- F** Finish
- 2 Electropolished
 - 12 Electropolished and hand buffed (bright)

Dimensions in millimeters (inch) unless otherwise stated

E3 VISE ACTION® Compression Latch

Large · Metal injection molding stainless steel housing · Fixed grip

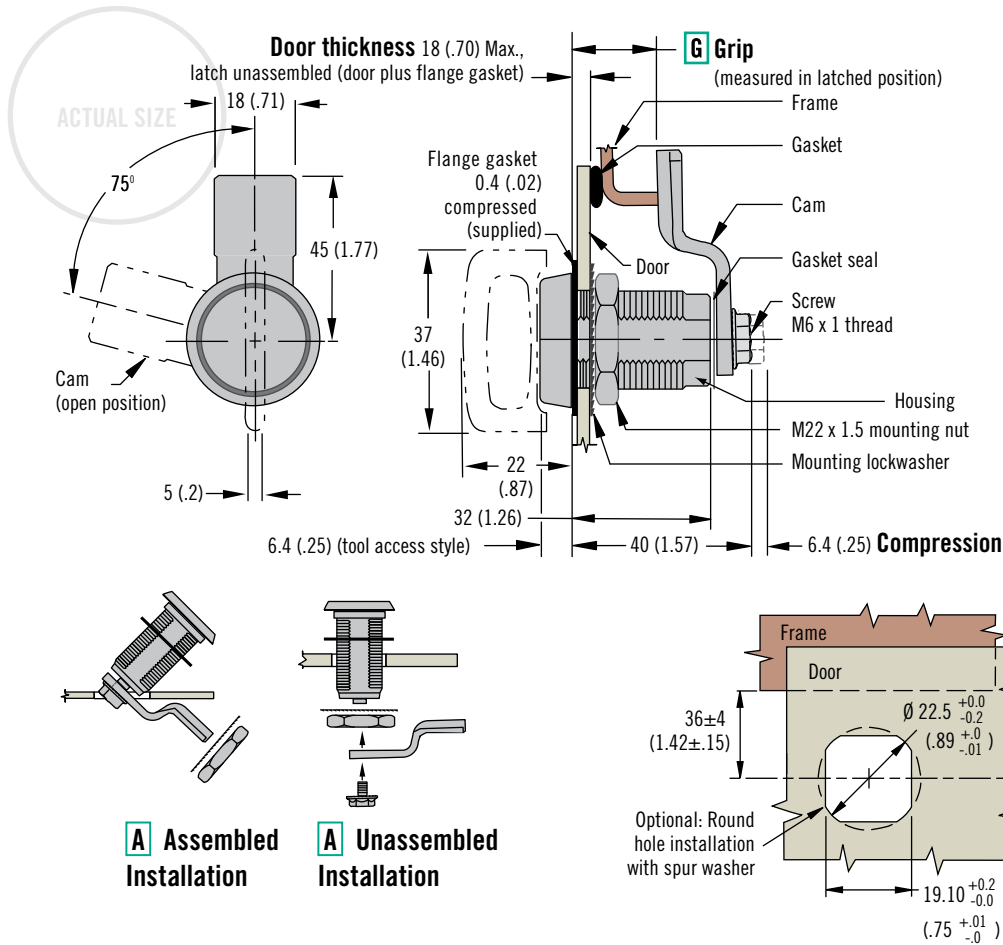

- Consistent pre-set compression
- Tool or hand operated
- Reduced internal protrusion

Material and Finish

Stainless steel 316 and 304

Performance Details

Max. static load: 445 N (100 lbf)

Sealing Notes

NEMA 4 / IP65 achieved using gasket supplied

Installation Notes

Recommended tightening torque for the mounting nut is 20 N·m (176 in·lbf), and for the mounting screw in 10 N·m (88 in·lbf)

Keys and Accessories

See pages 58 - 61

A Assembled Installation

A Unassembled Installation

- H** Head style
- 5 SOUTHCO® Tubular key
 - 6 8 (.32) Hex recess
 - 7 Knob
 - 9 Slotted recess
 - 10 8 (.32) Square
 - 11 Railway standard
 - 20 8 (.32) triangle
 - 37 3/8" Hex recess
 - 39 7 (.28) Tapered triangle

- F** Finish
- 2 Electropolished
 - 12 Electropolished and hand buffed (bright)

E3 - **A** **H** - **G** **F**

- A** Assembly status
- 10 Assembled
 - 12 Unassembled

Part Number Selection

Select grip from table, if your grip is between two options choose smaller.

Grip Table											
Total Grip	G	Max. Door Thickness for Assembled Latch	Total Grip	G	Max. Door Thickness for Assembled Latch	Total Grip	G	Max. Door Thickness for Assembled Latch	Total Grip	G	Max. Door Thickness for Assembled Latch
15 (.59)	00	Use unassembled	25 (.98)	05	5 (.20)	35 (1.38)	10	7 (.28)	45 (1.77)	15	7 (.28)
17 (.67)	01	Use unassembled	27 (1.06)	06	6 (.24)	37 (1.46)	11		47 (1.85)	16	
19 (.75)	02	1 (.04)	29 (1.14)	07	7 (.28)	39 (1.53)	12		49 (1.93)	17	
21 (.83)	03	2 (.08)	31 (1.22)	08		41 (1.61)	13		51 (2.01)	18	
23 (.91)	04	4 (.16)	33 (1.30)	09		43 (1.69)	14		53 (2.09)	19	



E3 VISE ACTION® Compression Latch

Aluminum · Tool Operated · Fixed grip

19.1mm size

- Light Weight
- Premium finish and corrosion resistance
- Reduced internal protrusion
- EN 45545-3 E30 Compliant

Material and Finish

Aluminum, Anodized or Powder Coated.

Black hard anodized assembly - Stainless Steel cam and hardware
All other finishes - Steel Cam and hardware

Performance Details

Maximum static load: 450 N (102 lbf)

Complies with DIN EN 61373 vibration standard
(See www.southco.com for details)

Sealing Notes

NEMA 4 and IP65 achieved using gasket supplied

Installation Notes

Recommended tightening torque for the mounting nut is 20 N·m (176 in·lbf), and for the mounting screw is 10 N·m (88 in·lbf)

Keys and accessories see page 90

Part Number Selection

Select grip from table, if your grip is between two options choose smaller.

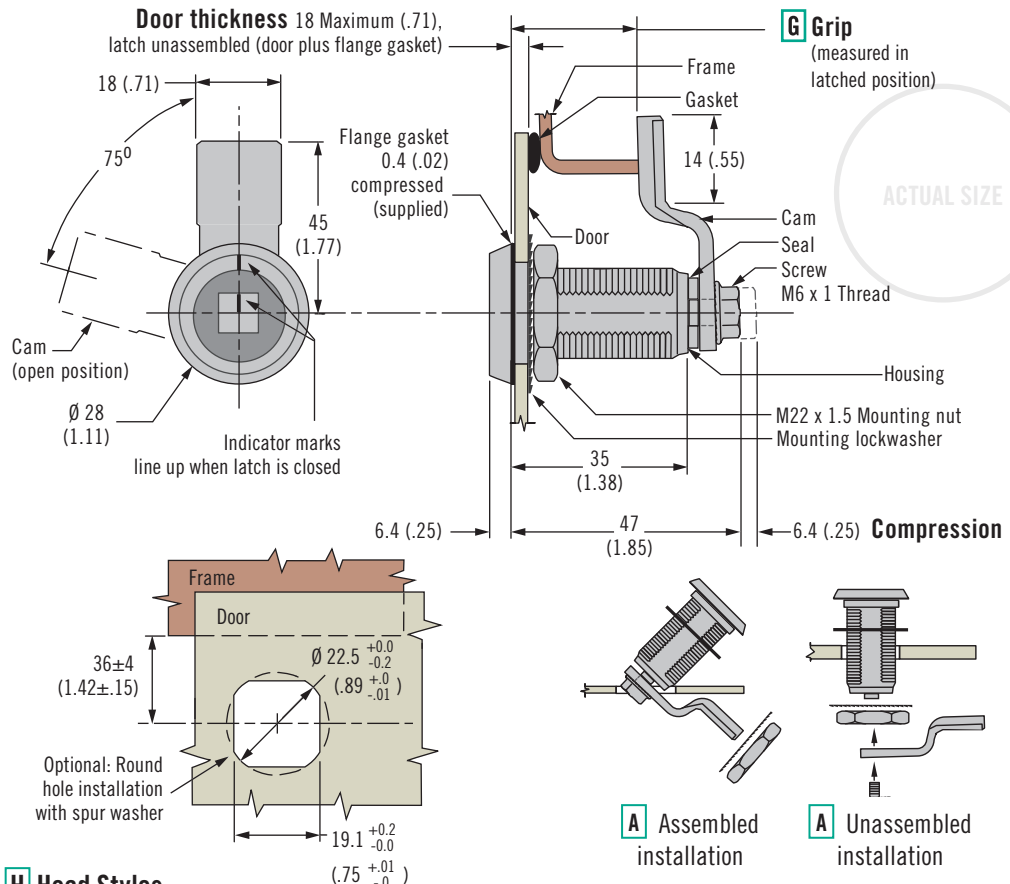

H Head Styles

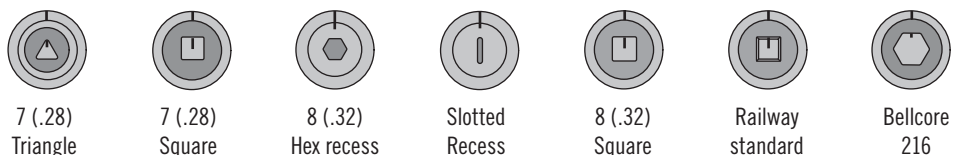

R Rotation

- 10 Type A clockwise to latch - Latch assembled
- 12 Type A clockwise to latch - Latch unassembled
- 27 Type B clockwise to latch - Latch assembled
- 29 Type B clockwise to latch - Latch unassembled

F Finish

- 59 Black Hard Anodized
- 06 Clear Powder Coat
- 56 Black Powder Coat
- 76 Silver Powder Coat

H Head style

- 3 7 (.28) Triangle
- 4 7 (.28) Square
- 6 8 (.32) Hex recess
- 9 Slotted Recess
- 10 8 (.32) Square
- 11 Railway standard
- 15 Bellcore 216

G Grip Table

Total Grip	G	Max. Door Thickness for Assembled Latch	Total Grip	G	Max. Door Thickness for Assembled Latch	Total Grip	G	Max. Door Thickness for Assembled Latch	Total Grip	G	Max. Door Thickness for Assembled Latch
20 (.79)	00	1 (.04)	30 (1.18)	05	7 (.28)	40 (1.57)	10	7 (.28)	50 (1.97)	15	7 (.28)
22 (.87)	01	2 (.08)	32.5 (1.28)	06		42 (1.65)	11		52 (2.05)	16	
24 (.94)	02	4 (.16)	34 (1.34)	07		44 (1.73)	12		54 (2.13)	17	
26 (1.02)	03	5 (.20)	36 (1.42)	08		46 (1.81)	13		56 (2.20)	18	
28 (1.10)	04	6 (.24)	38 (1.50)	09		48 (1.89)	14		58 (2.28)	19	

Dimensions in millimeters (inch) unless otherwise stated

Global Corporate Headquarters and Americas Customer Service & Technical Support Center
Tel: (1) 610-459-4000 · Fax: (1) 610-459-4012 · www.southco.com · info@southco.com

southco
CONNECT · CREATE · INNOVATE



www.southco.com/E3

© Southco E3Alu NA 07-13



E3 VISE ACTION® Compression Latch

Small · Metal injection molding stainless steel housing · Adjustable grip

- Consistent pre-set compression
- Easy grip adjustment
- Tool or hand operated
- Reduced dimensions

Material and Finish

Stainless steel 316 and 304

Performance Details

Max. static load: 356 N (80 lbf)

Sealing Notes

NEMA 4 / IP65 achieved using gasket supplied

Installation Notes

Caution: Position cam so latching function can be achieved comfortably by hand.

Accessories

See pages 58 - 61

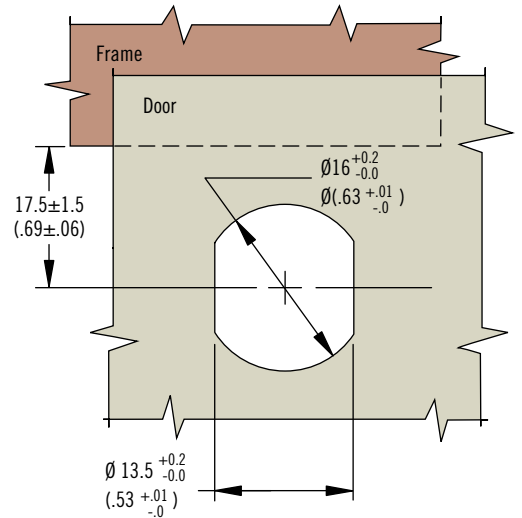
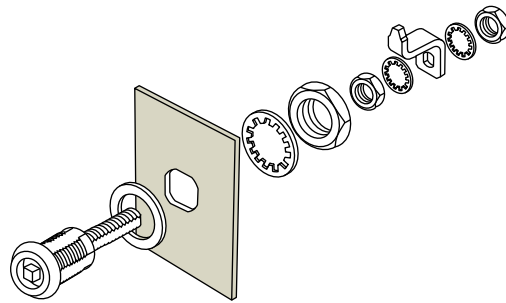
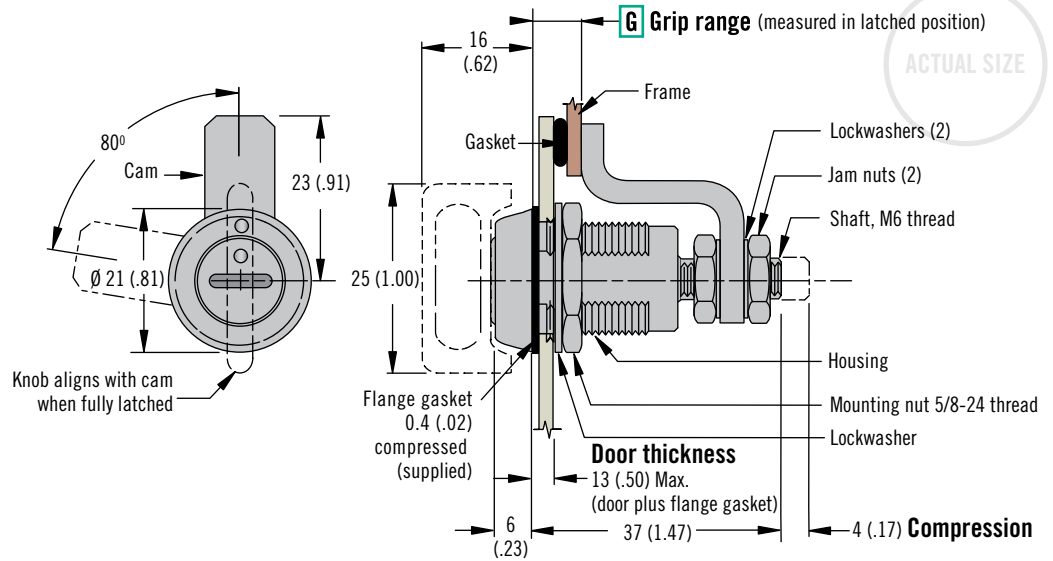

H Head Styles

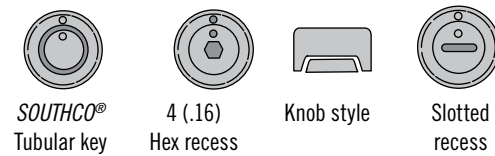

Part Number Selection

- H** Head style
- 5 SOUTHCO® Tubular key
 - 6 Hex recess
 - 7 Knob style
 - 9 Slotted recess

E3 - 5 H - G 2

G Grip	Min.	Max.
1	3.2 (.13)	6.4 (.25)
2	6.4 (.25)	9.5 (.37)
3	9.5 (.37)	12.7 (.50)
4	12.7 (.50)	15.9 (.63)
5	15.9 (.63)	19 (.75)
6	19 (.75)	22.2 (.87)
7	22.2 (.87)	25.4 (1)
8	25.4 (1)	28.6 (1.13)

Dimensions in millimeters (inch) unless otherwise stated

E3 VISE ACTION® Compression Latch

Small · Zinc and plated steel · Adjustable grip

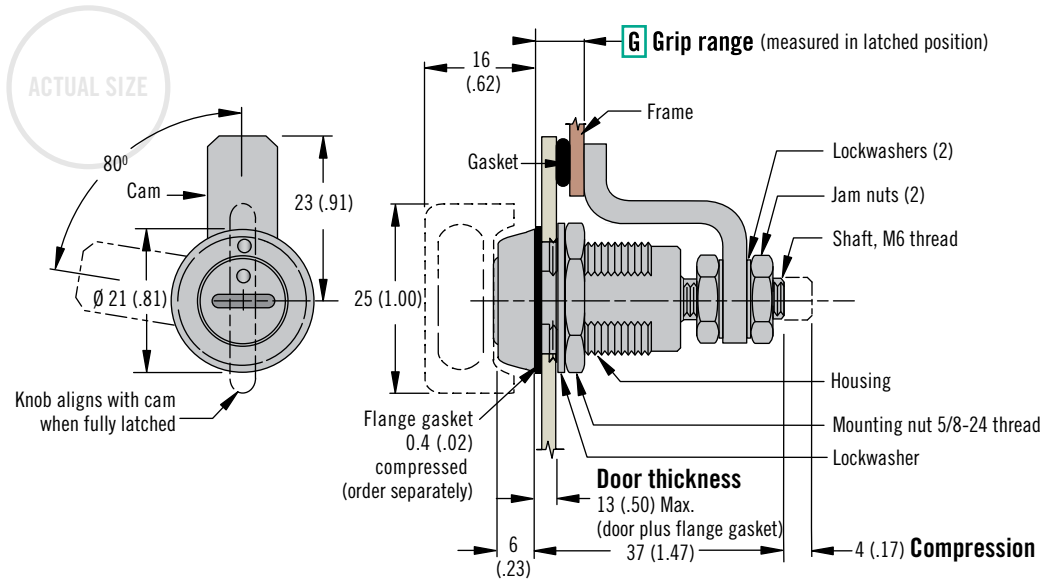

- Consistent pre-set compression
- Easy grip adjustment
- Tool or hand operated
- Reduced dimensions

Material and Finish

Zinc alloy, powder coated and steel, zinc plated

Performance Details

Max. static load: 330 N (75 lbf)

Sealing Notes

NEMA 4 / IP65 sealing is achieved by using optional flange gasket. Flange gasket part number: E3-0-30268-02

Installation Notes

Caution: Position cam so latching function can be achieved comfortably by hand.

Accessories

See pages 58 - 61

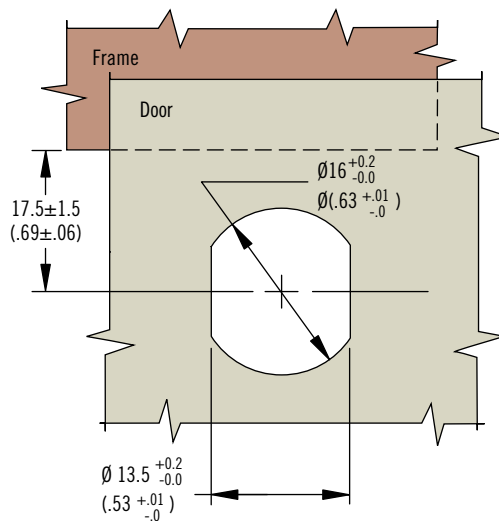
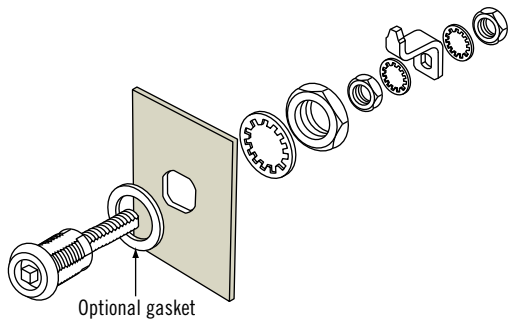

H Head Styles

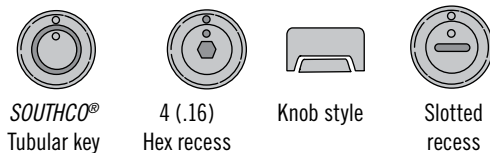

H Head style

- 5 SOUTHCO® Tubular key
- 6 Hex recess
- 7 Knob style
- 9 Slotted recess

E3 - 5 H - G F

F Finish

- 1 Chrome plated
- 5 Black powder coated
- 7 Silver powder coated

G Grip	Min.	Max.
1	3.2 (.13)	6.4 (.25)
2	6.4 (.25)	9.5 (.37)
3	9.5 (.37)	12.7 (.50)
4	12.7 (.50)	15.9 (.63)
5	15.9 (.63)	19 (.75)
6	19 (.75)	22.2 (.87)
7	22.2 (.87)	25.4 (1)
8	25.4 (1)	28.6 (1.13)

Part Number Selection



Dimensions in millimeters (inch) unless otherwise stated



www.southco.com/E3



E3 VISE ACTION® Compression Latch

Large · Zinc and plated steel · Tool operated · Adjustable grip

- Consistent pre-set compression
- Easy grip adjustment
- Tool operated for security

Material and Finish

Zinc alloy, powder coated or chrome plated and steel, zinc plated

Performance Details

Max. static load: 450 N (100 lbf)

Sealing Notes

NEMA 4 / IP65 sealing is achieved by using optional flange gasket. Flange gasket part number: E5-17

Installation Notes

Caution: Position cam so latching function can be achieved comfortably by hand. Recommended tightening torque for the mounting nut is 20 N·m (176 in·lbf).

Keys and Accessories

See pages 58 - 61

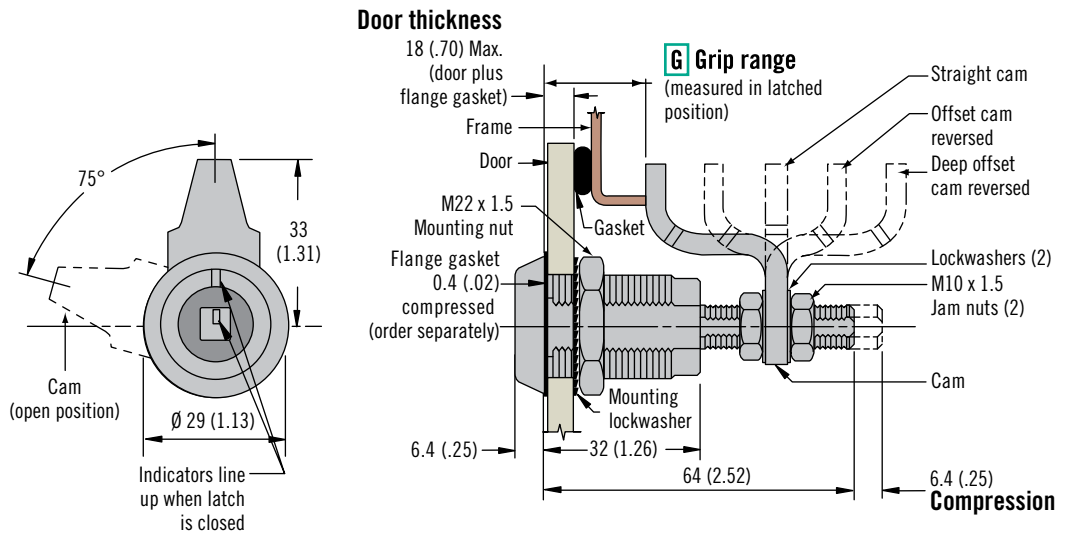

Railway Standard - Bellcore 216

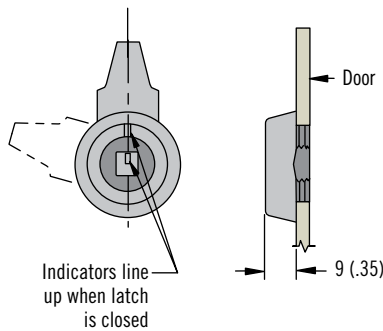

All Other Head Styles (slotted recess shown)

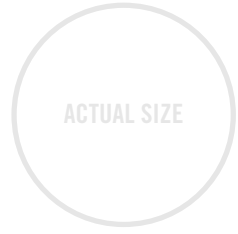
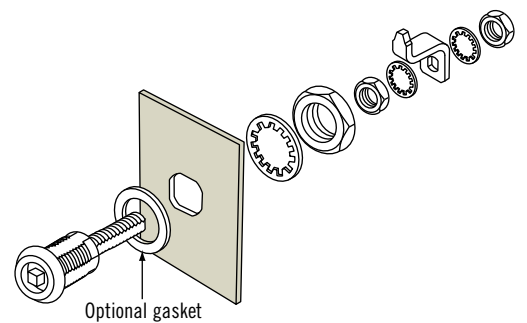
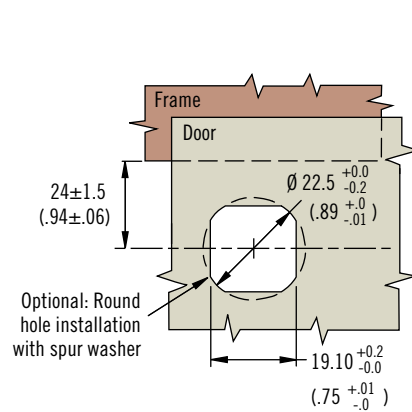
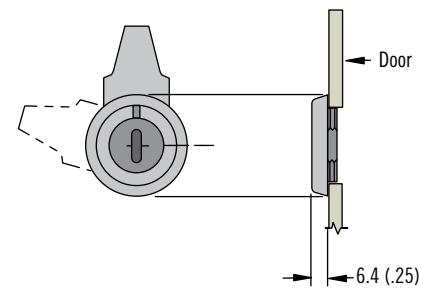

H Head Styles (other head styles available)



Part Number Selection

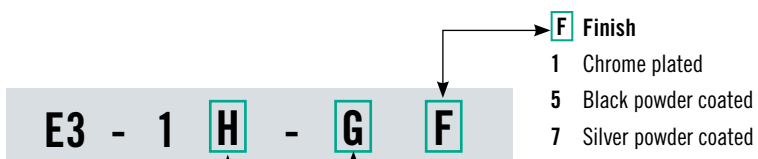

- H** Head style
- 2 3 (.11) Double bit
 - 3 7 (.28) Triangle
 - 4 7 (.28) Square
 - 5 SOUTHCO® Tubular key
 - 6 8 (.32) Hex recess
 - 9 Slotted recess
 - 10 8 (.32) Square driver
 - 11 Railway standard
 - 15 Bellcore 216
 - 16 Bellcore electronics
 - 20 8 (.32) Triangle
 - 48 5 (.19) Double bit

G Grip	Min.	Max.	Cam Type
1	11.4 (.45)	27.2 (1.07)	Deep offset cam, forward
	66.3 (2.61)	76.2 (3.00)	Deep offset cam, reversed
2	25.4 (1)	41.1 (1.62)	Offset cam, forward
	52.6 (2.07)	68.3 (2.69)	Offset cam, reversed
3	38.9 (1.53)	54.6 (2.15)	Straight cam



E3 VISE ACTION® Compression Latch

Large · Zinc and plated steel · Hand operated · Adjustable grip

- Consistent pre-set compression
- Easy grip adjustment
- Hand operated

Material and Finish

Zinc alloy, powder coated or chrome plated and steel, zinc plated

Performance Details

Max. static load: 450 N (100 lbf)

Sealing Notes

NEMA 4 / IP65 sealing is achieved by using optional flange gasket. Flange gasket part number: E5-17

Installation Notes

Caution: Position cam so latching function can be achieved comfortably by hand. Recommended tightening torque for the mounting nut is 20 N·m (176 in·lbf).

Keys and Accessories

Key CH751 page 58
Washers and sleeve nut see page 60

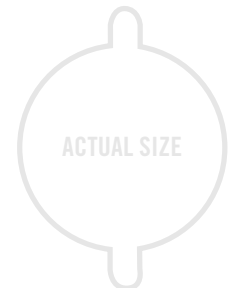
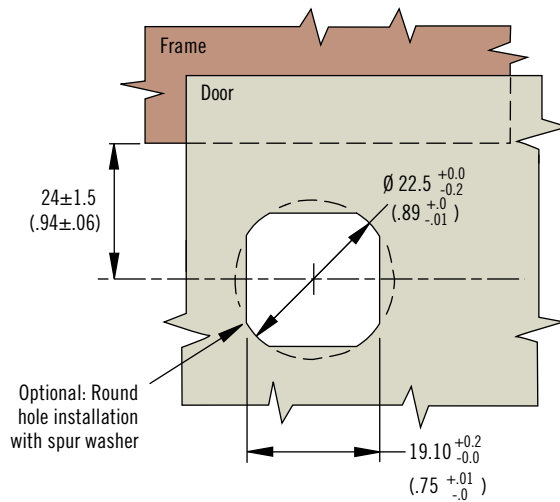
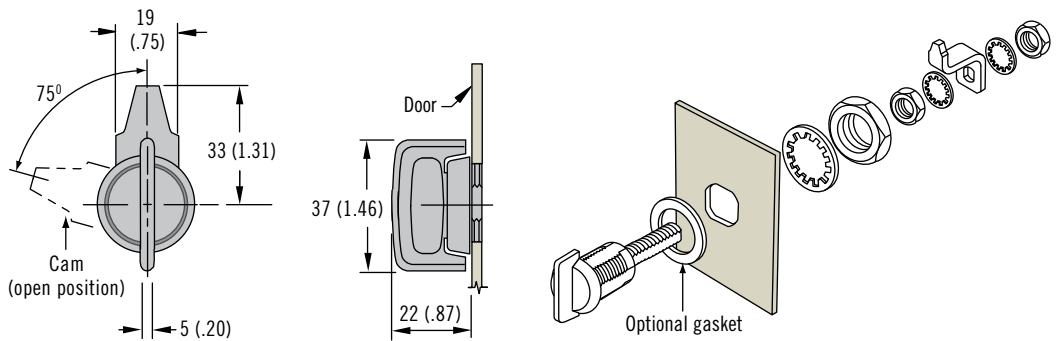
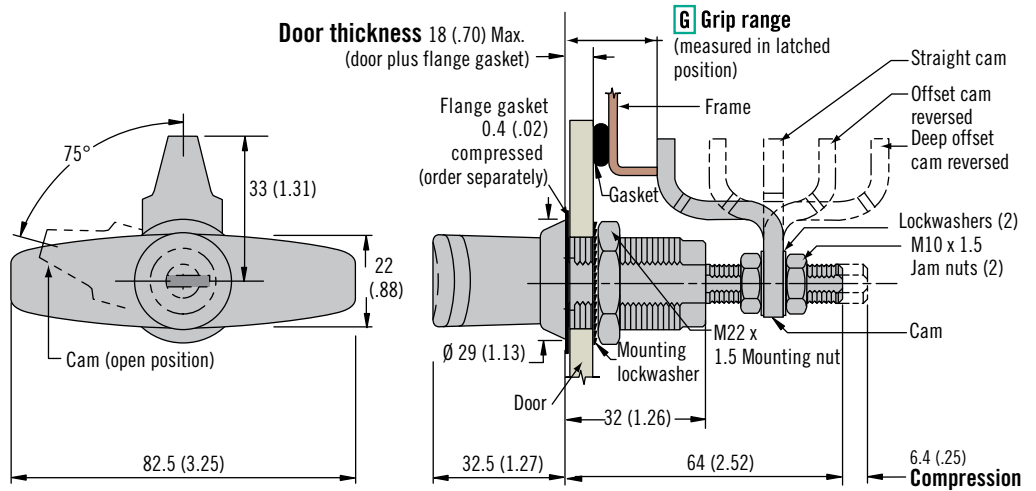

Dimensions in millimeters (inch) unless otherwise stated

H Head Styles



Standard knob



T-handle, key-locking



T-handle, non-locking

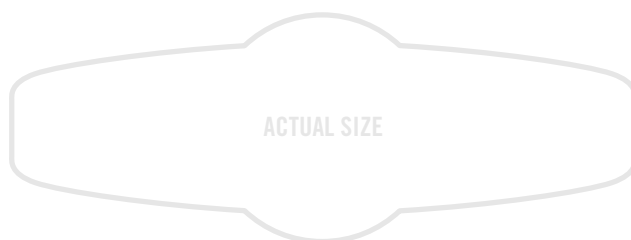

Part Number Selection

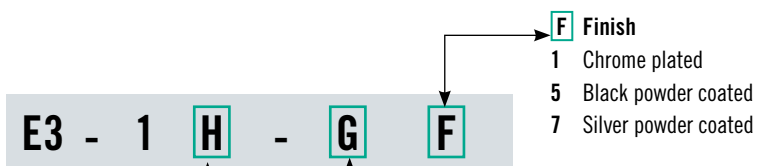

- H** Head style
- 1 T-handle, non-locking
 - 7 Standard knob
 - 8 T-Handle, key-locking keyed CH751 (two flat keys supplied)

G Grip	Min.	Max.	Cam Type
1	11.4 (.45)	27.2 (1.07)	Deep offset cam, forward
	66.3 (2.61)	76.2 (3.00)	Deep offset cam, reversed
2	25.4 (1)	41.1 (1.62)	Offset cam, forward
	52.6 (2.07)	68.3 (2.69)	Offset cam, reversed
3	38.9 (1.53)	54.6 (2.15)	Straight cam



E3 VISE ACTION® Compression Latch

Large · Zinc and plated steel · Tool operated · Fixed grip

- Consistent pre-set compression
- Quick install
- Reduced internal protrusion

Material and Finish

Zinc alloy, powder coated or chrome plated and steel plated

Performance Details

Max. static load: 300 N (67 lbf)

Sealing Notes

NEMA 4 / IP65 sealing is achieved by using optional flange gasket. Flange gasket part number: E5-17

Installation Notes

Recommended tightening torque for the mounting nut is 20 N·m (176 in·lbf), and for the mounting screw in 10 N·m (88 in·lbf)

Keys and Accessories

See pages 58 - 61

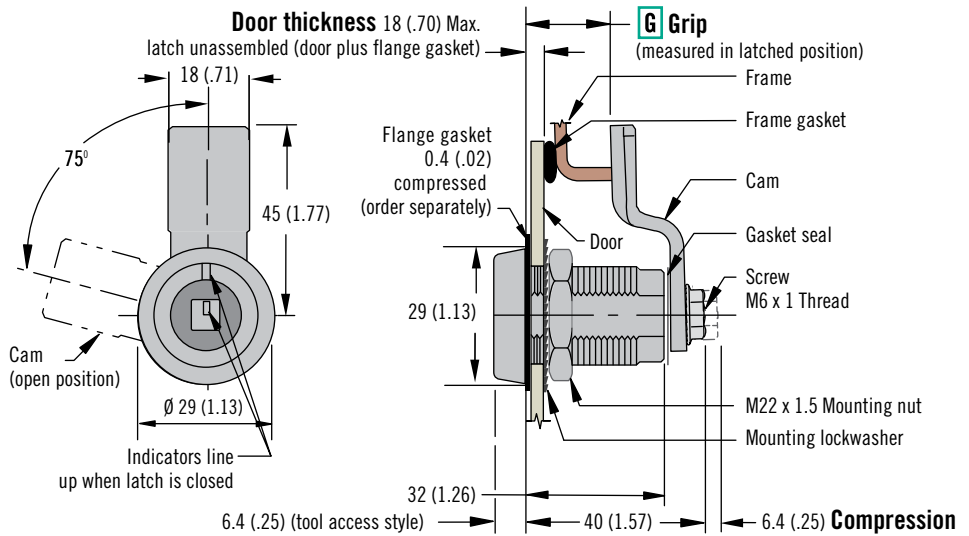

Railway Standard - Bellcore 216

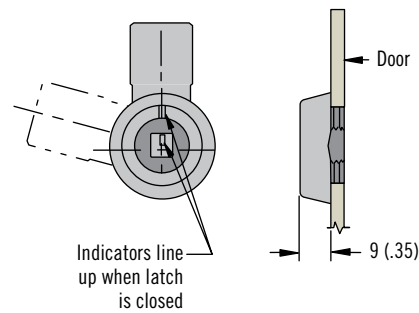

All Other Head Styles (slotted recess shown)

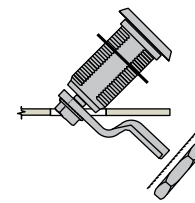
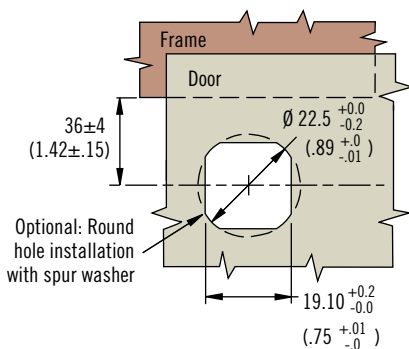
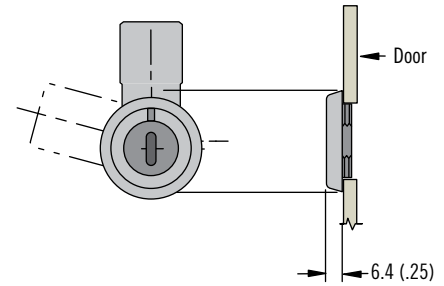

A Assembled Installation

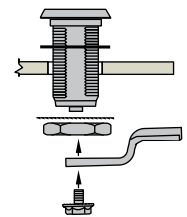

A Unassembled Installation

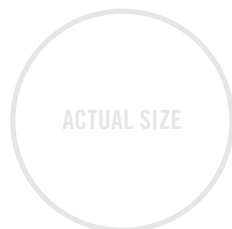

Dimensions in millimeters (inch) unless otherwise stated

H Head Styles



Part Number Selection

H Head style

- 2 3 (.11) Double bit
- 3 7 (.28) Triangle
- 4 7 (.28) Square
- 5 SOUTHCO® Tubular key
- 6 8 (.32) Hex recess
- 9 Slotted recess
- 10 8 (.32) Square driver
- 11 Railway standard
- 15 Bellcore 216
- 16 Bellcore electronics
- 20 8 (.32) Triangle
- 48 5 (.19) Double bit

F Finish

- 1 Chrome plated
- 5 Black powder coated
- 7 Silver powder coated

E3 - **A** **H** - **G** **F**

A Assembly status

- 10 Assembled
- 12 Unassembled

G Grip Table

Total Grip	G	Max. Door Thickness for Assembled Latch	Total Grip	G	Max. Door Thickness for Assembled Latch	Total Grip	G	Max. Door Thickness for Assembled Latch	Total Grip	G	Max. Door Thickness for Assembled Latch
15 (.59)	00	Use unassembled	25 (.98)	05	5 (.20)	35 (1.38)	10	7 (.28)	45 (1.77)	15	7 (.28)
17 (.67)	01	Use unassembled	27 (1.06)	06	6 (.24)	37 (1.46)	11		47 (1.85)	16	
19 (.75)	02	1 (.04)	29 (1.14)	07	7 (.28)	39 (1.53)	12		49 (1.93)	17	
21 (.83)	03	2 (.08)	31 (1.22)	08		41 (1.61)	13		51 (2.01)	18	
23 (.91)	04	4 (.16)	33 (1.30)	09		43 (1.69)	14		53 (2.09)	19	



E3 VISE ACTION® Compression Latch

Large · Zinc and plated steel · Hand operated · Fixed grip

- Consistent pre-set compression
- Quick install
- Reduced internal protrusion

Material and Finish

Zinc alloy, powder coated or chrome plated and steel, zinc plated

Performance Details

Max. static load: 300 N (67 lbf)

Sealing Notes

NEMA 4 / IP65 sealing is achieved by using optional flange gasket. Flange gasket part number: E5-17

Installation Notes

Recommended tightening torque for the mounting nut is 20 N·m (176 in·lbf), and for the mounting screw in 10 N·m (88 in·lbf)

Keys and Accessories

Key CH751 page 58

Washers and sleeve nut see page 60

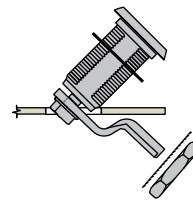
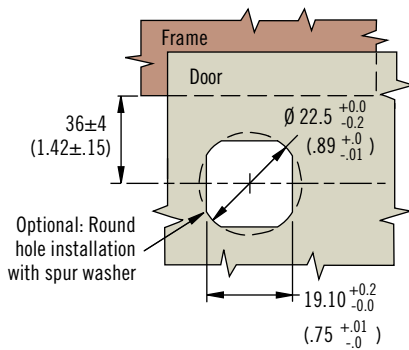
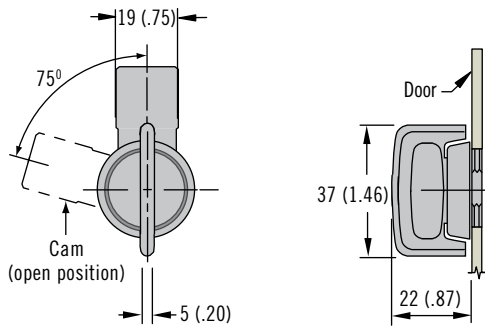
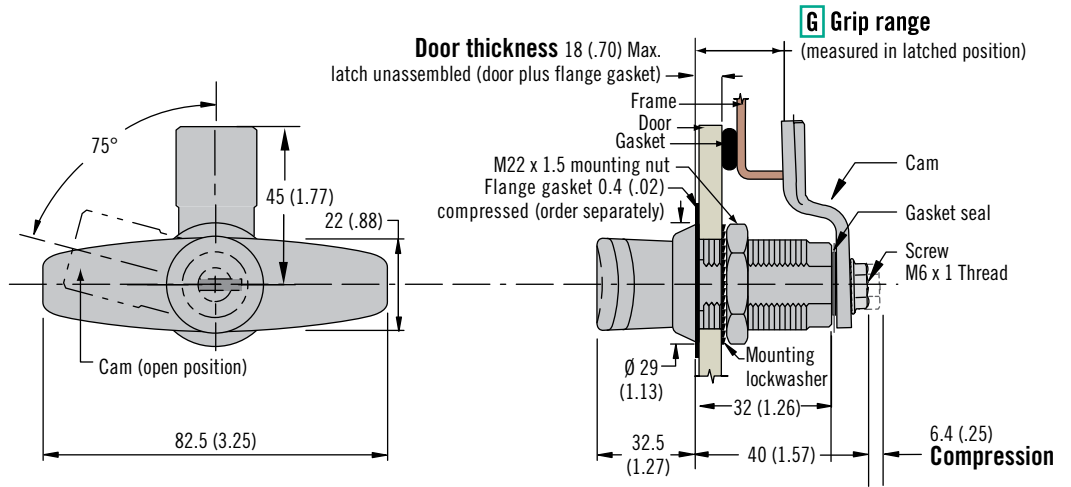

A Assembled Installation

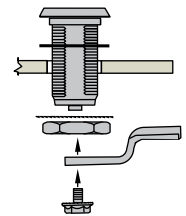

A Unassembled Installation

H Head Styles



Standard knob



T-handle, key-locking



T-handle, non-locking

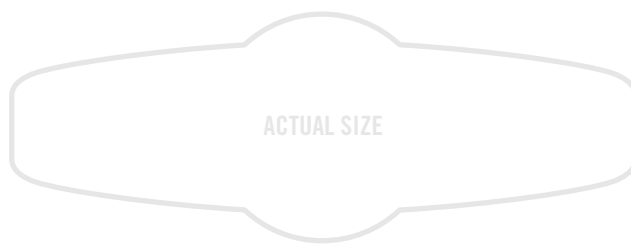
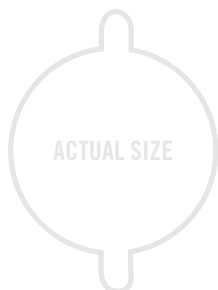

Part Number Selection

H Head style

- 1 T-handle, non-locking
- 7 Standard knob
- 8 T-Handle, key-locking keyed CH751 (two flat keys supplied)

F Finish

- 1 Chrome plated
- 5 Black powder coated
- 7 Silver powder coated

E3 - **A** **H** - **G** **F**

A Assembly status

- 10 Assembled
- 12 Unassembled

G Grip Table

Total Grip	G	Max. Door Thickness for Assembled Latch	Total Grip	G	Max. Door Thickness for Assembled Latch	Total Grip	G	Max. Door Thickness for Assembled Latch	Total Grip	G	Max. Door Thickness for Assembled Latch
15 (.59)	00	Use unassembled	25 (.98)	05	5 (.20)	35 (1.38)	10	7 (.28)	45 (1.77)	15	7 (.28)
17 (.67)	01	Use unassembled	27 (1.06)	06	6 (.24)	37 (1.46)	11		47 (1.85)	16	
19 (.75)	02	1 (.04)	29 (1.14)	07	7 (.28)	39 (1.53)	12		49 (1.93)	17	
21 (.83)	03	2 (.08)	31 (1.22)	08		41 (1.61)	13		51 (2.01)	18	
23 (.91)	04	4 (.16)	33 (1.30)	09		43 (1.69)	14		53 (2.09)	19	



E3 VISE ACTION® Compression Latch

Large · Zinc and plated steel · Wing knob · Adjustable grip

- Consistent pre-set compression
- Easy grip adjustment
- Multiple key codes

Material and Finish

Zinc alloy, powder coated and steel, zinc plated

Performance Details

Max. static load: 450 N (100 lbf)

Sealing Notes

NEMA 4 / IP65 sealing is achieved by using gasket supplied.

Installation Notes

Caution: Position cam so latching function can be achieved comfortably by hand. Recommended tightening torque for the mounting nut is 20 N·m (176 in·lbf).

Keys and Accessories

Key CH751 page 58

Key R001 page 58

Washers and sleeve nut see page 60

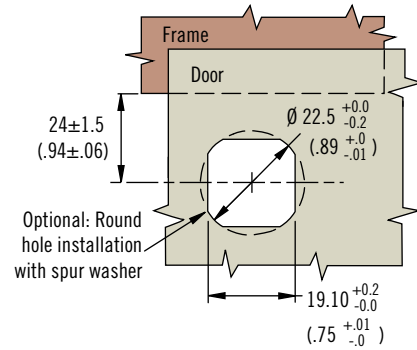
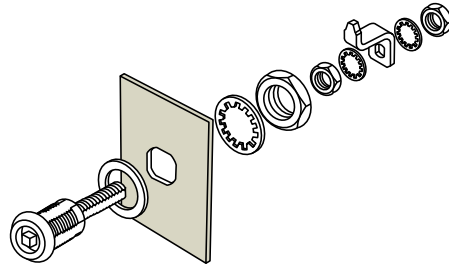
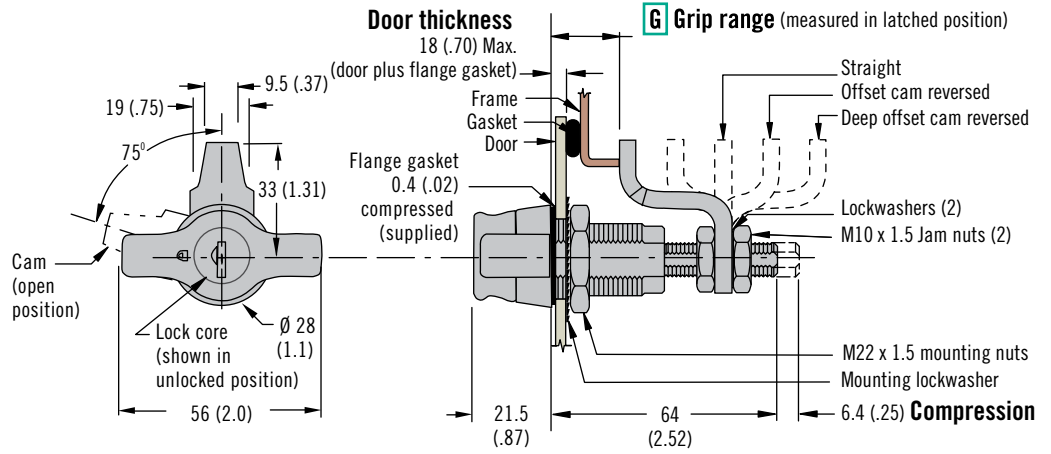

L Lock Styles



Wing knob, non-locking

Wing knob, key-locking, keyed CH751

Wing knob, key-locking, shuttered, keyed R001

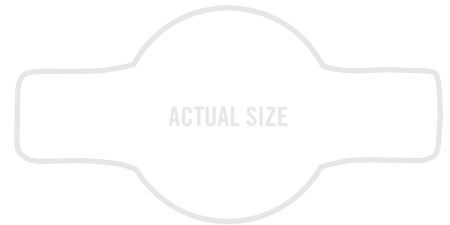

Part Number Selection

L Lock style

- 50 Wing knob, non-locking
- 51 Wing knob, key-locking, keyed CH751 (1 overmolded key supplied)
- 58 Wing knob, key-locking, keyed R001 (1 overmolded key supplied)

G Grip	Min.	Max.	Cam Type
1	11.4 (.45)	27.2 (1.07)	Deep offset cam, forward
	66.3 (2.61)	76.2 (3.00)	Deep offset cam, reversed
2	25.4 (1)	41.1 (1.62)	Offset cam, forward
	52.6 (2.07)	68.3 (2.69)	Offset cam, reversed
3	38.9 (1.53)	54.6 (2.15)	Straight cam

E3 - 1 L - G 5

Dimensions in millimeters (inch) unless otherwise stated



www.southco.com/E3

E3 VISE ACTION® Compression Latch

Large · Zinc and plated steel · Wing knob · Fixed grip



- Consistent pre-set compression
- Minimal internal protrusion
- Multiple key codes

Material and Finish

Zinc alloy, powder coated and steel, zinc plated

Performance Details

Max. static load: 300 N (67 lbf)

Sealing Notes

NEMA 4 / IP65 sealing is achieved by using gasket supplied.

Installation Notes

Recommended tightening torque for the mounting nut is 20 N·m (176 in·lbf), and for the mounting screw in 10 N·m (88 in·lbf)

Keys and Accessories

Key CH751 page 58

Key R001 page 58

Washers and sleeve nut see page 60

Part Number Selection

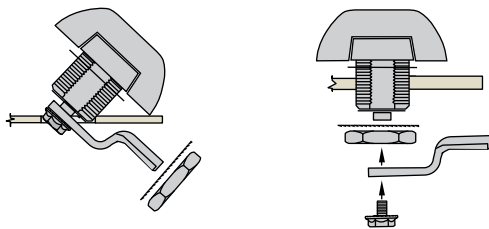
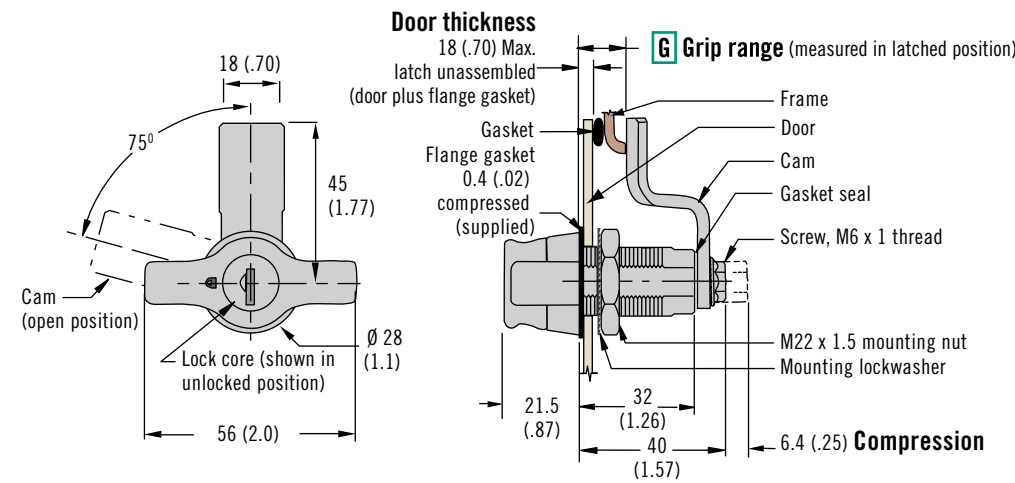

A Assembled Installation

A Unassembled Installation

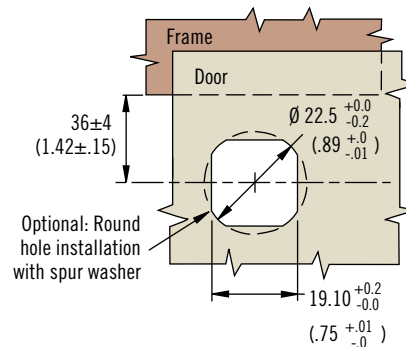

ACTUAL SIZE

- | | |
|--------------------------|--|
| A Assembly status | L Lock style |
| 10 Assembled | 50 Wing knob, non-locking |
| 12 Unassembled | 51 Wing knob, locking, keyed CH751 (1 overmolded key supplied) |
| | 58 Wing knob, locking, keyed R001 (1 overmolded key supplied) |

E3 - A L - G 5

G Grip Table

Total Grip	G	Max. Door Thickness for Assembled Latch	Total Grip	G	Max. Door Thickness for Assembled Latch	Total Grip	G	Max. Door Thickness for Assembled Latch	Total Grip	G	Max. Door Thickness for Assembled Latch
15 (.59)	00	Use unassembled	25 (.98)	05	5 (.20)	35 (1.38)	10	7 (.28)	45 (1.77)	15	7 (.28)
17 (.67)	01	Use unassembled	27 (1.06)	06	6 (.24)	37 (1.46)	11		47 (1.85)	16	
19 (.75)	02	1 (.04)	29 (1.14)	07	7 (.28)	39 (1.53)	12		49 (1.93)	17	
21 (.83)	03	2 (.08)	31 (1.22)	08		41 (1.61)	13		51 (2.01)	18	
23 (.91)	04	4 (.16)	33 (1.30)	09		43 (1.69)	14		53 (2.09)	19	



E3 VISE ACTION® Compression Latch

Large · Zinc and plated steel · Tool & hand operated
 Three hole mount · Adjustable grip

- Consistent pre-set compression
- Easy grip adjustment

Material and Finish

Zinc alloy, powder coated or chrome plated and steel, zinc plated

Performance Details

Max. static load: 450 N (100 lbf)

Installation Notes

For door thickness greater than 4 (.16) calculate screw length using the following formula:
 Door thickness + 6 (.24)

Keys and Accessories

Pages 58 - 61

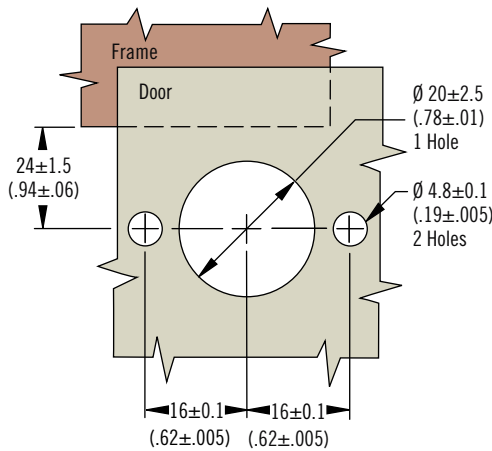
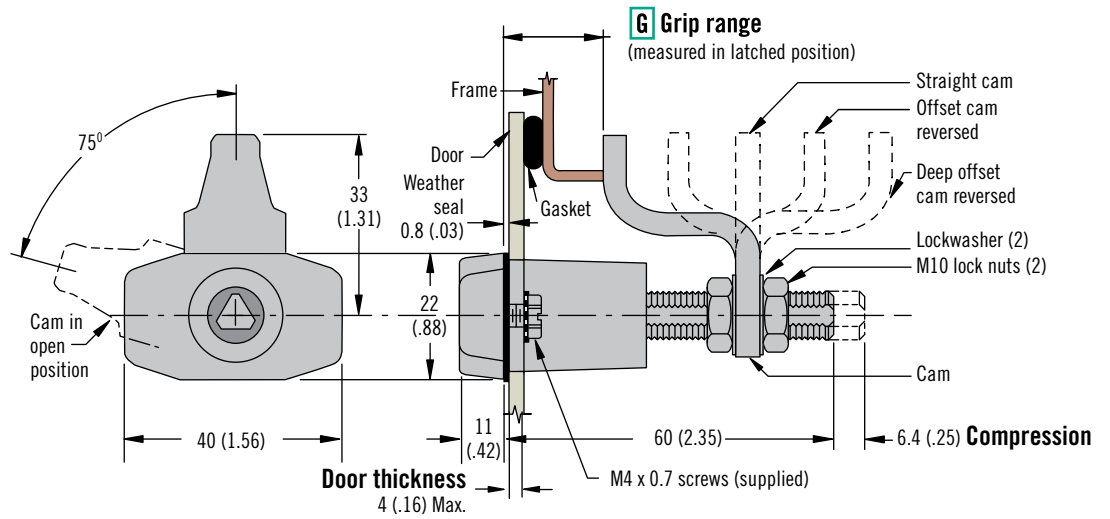

H Head Styles

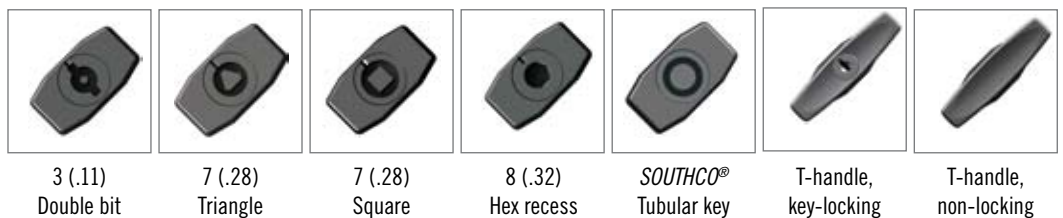

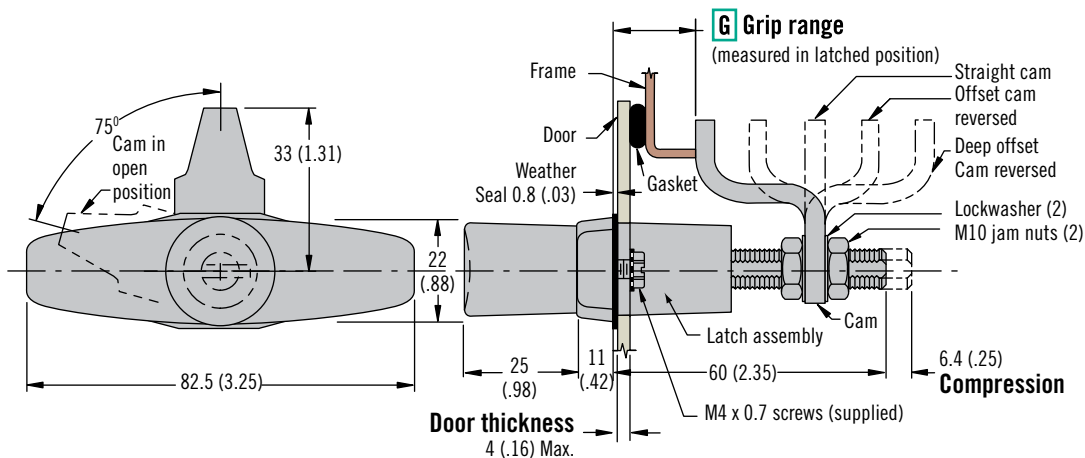

Part Number Selection

H Head style

- 1 T-handle non-locking
- 2 3 (.11) Double bit
- 3 7 (.28) Triangle
- 4 7 (.28) Square
- 5 SOUTHCO® Tubular key
- 6 8 (.32) Hex recess
- 8 T-Handle locking keyed CH751 (two flat keys supplied)

F Finish

- 1 Chrome plated
- 5 Black powder coated
- 7 Silver powder coated

E3 - 3 **H** - **G** **F**

G Grip	Min.	Max.	Cam Type
1	7.9 (.31)	23.6 (.93)	Deep offset cam, forward
	62.7 (2.47)	76.2 (3.00)	Deep offset cam, reversed
2	21.8 (.86)	37.3 (1.47)	Offset cam, forward
	49 (1.93)	64.8 (2.55)	Offset cam, reversed
3	35.3 (1.39)	51 (2.00)	Straight cam





E3 VISE ACTION® Compression Latch Accessories

Keys

Material and Finish

Steel, zinc plated

Part Number

Steel tubular key (order separately)
 Small E3 latches: E3-26-819-15
 Large E3 latches: E3-5-15

Material and Finish

Zinc alloy or nylon

Keys - Steel

For latches with *SOUTHCO*®
 Tubular key head styles

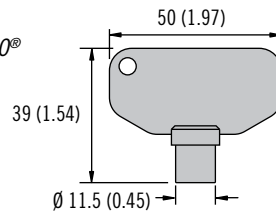

Keys - Zinc or Nylon

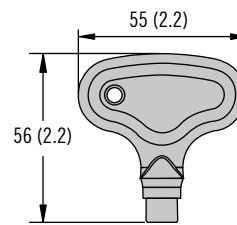

H Head style

- 2 3 (.11) Double bit
- 3 7 (.28) Triangle
- 4 7 (.28) Square
- 7 8 (.32) Triangle
- 8 8 (.32) Square recess
- 9 5 (.19) Double bit (nylon only)
- 10 8 (.32) Square male (zinc only)
- 11 Bellcore electronics
- 12 Bellcore 216 (zinc only)
- 24 6 (.24) Square recess (nylon only)

F Finish

- 1 Plated zinc
- 2 Natural zinc
- 3 Nylon black

E3 - H - F

Key Styles

- 2 3 (.11) Double bit
- 3 7 (.28) Triangle
- 4 7 (.28) Square
- 7 8 (.32) Triangle
- 8 8 (.32) Square recess
- 9 5 (.19) Double bit
- 10 8 (.32) Square male
- 11 Bellcore electronics
- 12 Bellcore 216
- 24 6 (.24) Square recess

Part Number

Overmolded key CH751:
 Single: PK-10-10-05
 Pair: PK-10-01-05

Overmolded key R001:
 Single: PK-10-10-05-KR001
 Pair: PK-10-01-05-KR001

Flat key
 Pair: PK-10-01

Overmolded Keys

Key CH751

Key R001



Flat Keys

Key CH751



www.southco.com/E3

Dimensions in millimeters (inch) unless otherwise stated

E3 VISE ACTION® Compression Latch Accessories

Fixed bracket for flush mounting

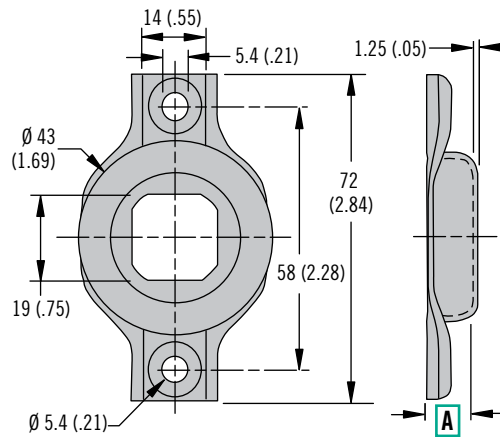
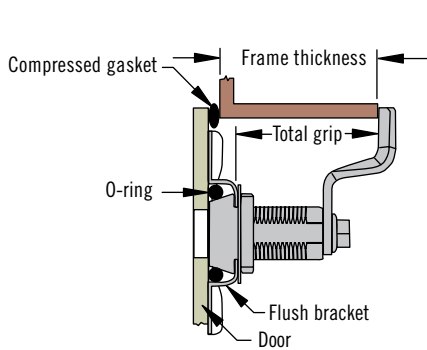

A	Part Number	Material
6.6	E3-77-251-12	Galvanized steel
*9.3	E3-77-252-12	Galvanized steel
6.6	E3-77-251-24	304 Stainless steel
*9.3	E3-77-252-24	304 Stainless steel
* For use with Railway standard or Bellcore 216 style only		

To calculate the **Total Grip**, use the following formula:

Frame Thickness + Compressed Gasket - A

Use this **Total Grip** with the appropriate E3 tables in the *SOUTHCO® Handbook* to determine cam type.

Material and Finish

Stainless steel or galvanized steel with rubber o-ring

Sealing Notes

Environmental sealing is achieved by using latch with flange gasket (optional or included with latch see pages 40 -55) and sealing the mounting screw threads.

Notes

For use with large single hole mount tool operated E3 VISE ACTION® compression latches, see pages 40 - 43, 46 - 47 and 50 - 51

Door preparation

For **B** dimensions:

Large adjustable grip 24 ± 1.5 (.94 ± .06)

Fixed grip 36 ± 4 (1.42 ± .15)

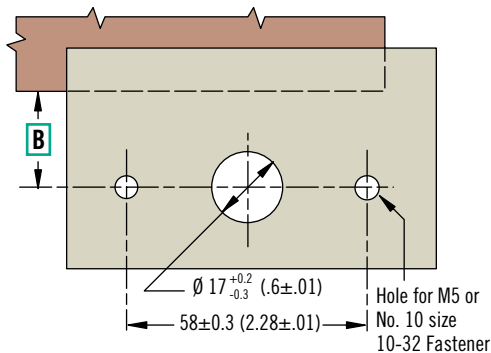

Double bit (key retained style)

Key can only be removed in the latch closed position.

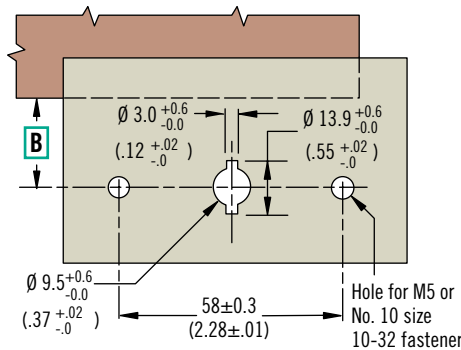

Installation

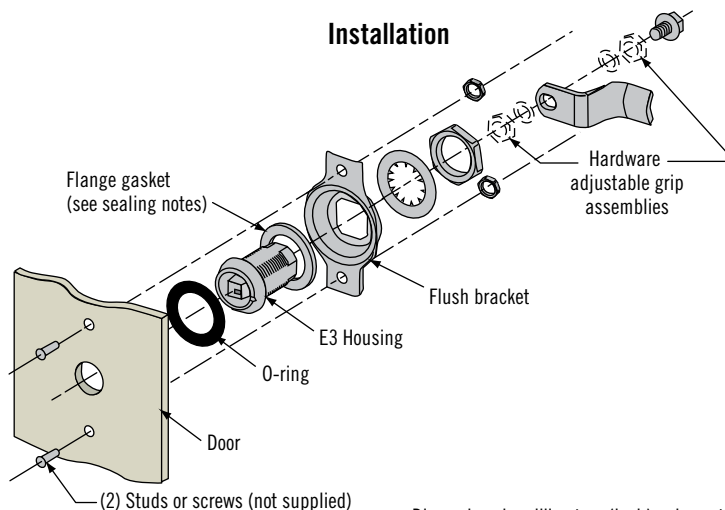



E3 VISE ACTION® Compression Latch Accessories

Sealing & spur washers · Sealing covers · Sleeve nut

Material and Finish

Sealing washers: Neoprene, natural

Spur washer: Steel, zinc plated

Sealing cover: Thermoplastic elastomer, black

Notes

Spur washer provides for round hole installation in wood and similar materials of low density

Sealing cover cannot be used with Railway standard or Bellcore 216 styles

Sealing Washers

Small

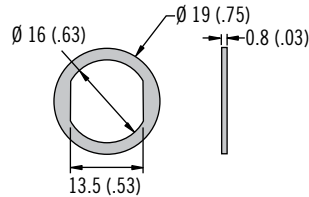

Large

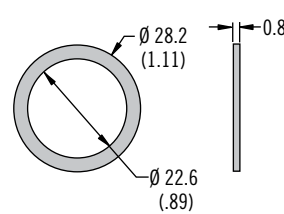

Spur Washer

Large

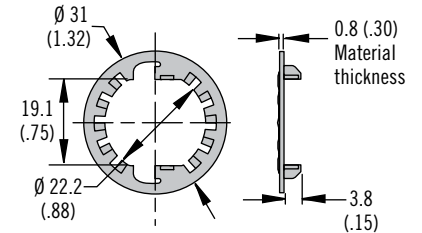

Sealing Cover

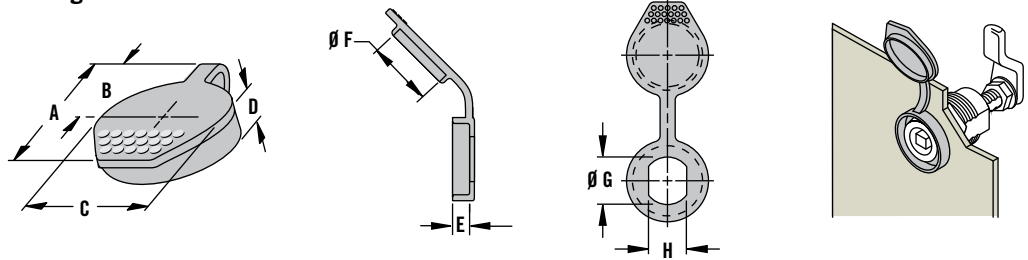

Latch Installation Hole Size		Dimensions					
Ø G	Distance across flat H	A	B	Ø C	D	E	Ø F
16 (.63)	13.5 (.53)	40 (1.58)	20 (.85)	29 (1.13)	10.5 (.42)	6.1 (.24)	22.3 (.88)
22.5 (.88)	19.6 (.77)	47 (1.84)	28 (1.09)	35 (1.38)	11.7 (.46)	6.9 (.27)	28.7 (1.13)

Part Number

See table

Type	Part Number	Adjustment Formula
Sealing washer small	E3-0-30268-02	Add 0.4 (.02) to door thickness
Sealing washer large	E5-17	Add 0.4 (.02) to door thickness
Spur washer large	90-6-875	Add 0.8 (.03) to door thickness
Sealing cover small	90-1	Add 2.3 (.09) to door thickness
Sealing cover large	90-3	Add 2.3 (.09) to door thickness

Material and Finish

Zinc alloy

Installation Notes

For use in double skin doors. Produce standard panel cutout in outer door and for the inner door produce 25 (.98) hole for sleeve nut.

Part Number

See table

Sleeve Nut M22 Thread (for large E3 only)

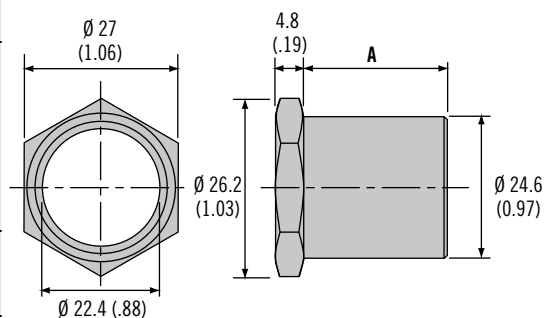

A	Part Number
12.7 (.50)	E3-34-263-36
25 (.98)	E3-34-264-36

Dimensions in millimeters (inch) unless otherwise stated



www.southco.com/E3

southco
CONNECT · CREATE · INNOVATE

E3 VISE ACTION® Compression Latch Accessories

Padlock brackets · Finger pulls



Padlock Bracket (Square)

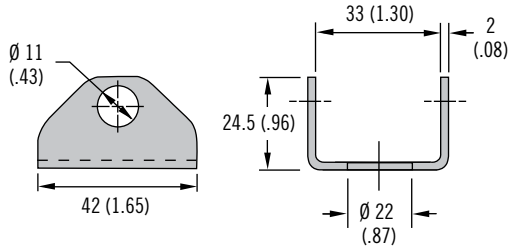

Padlock Bracket (Round)

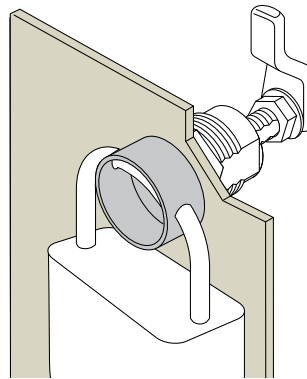
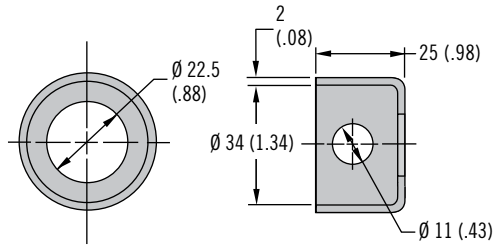

Material and Finish

Padlock bracket: Stainless steel, black powder coated
 Pull tab: Nylon, black

Sealing Notes

To provide sealing use two flange gaskets and add compressed thickness of each flange gasket and bracket thickness to your door thickness.

Notes

Padlock bracket: For large size single hole mount tool operated only
 Only unassembled styles can be used with round padlock bracket

Pull Tab (Small)

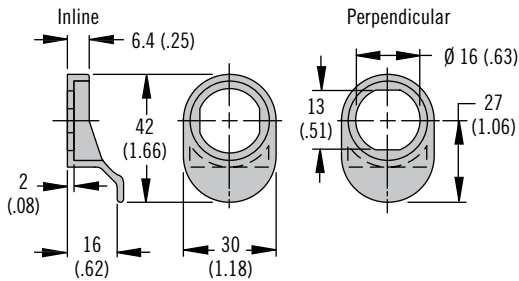

Pull Tab (Large)

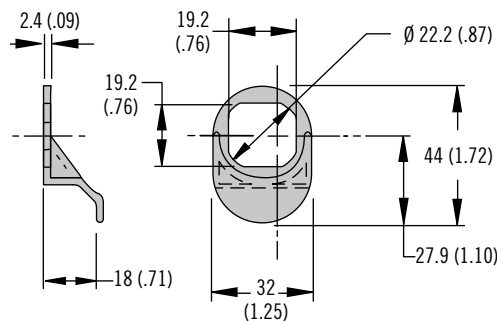

Pull tab in-line with cam

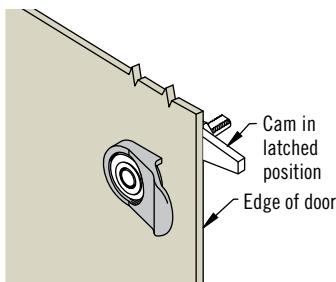

Pull tab perpendicular to cam

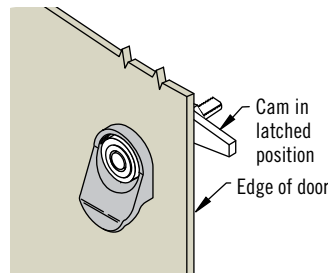

Type	Part Number	Adjustment Formula
Padlock bracket square	E3-77-101-31	Add 2 (.08) to door thickness
Padlock bracket round	E3-77-102-31	Add 2 (.08) to door thickness
Pull tab small - In-line	E3-27-61	Add 2 (.08) to door thickness
Pull tab small - Perpendicular	E3-27-62	Add 2 (.08) to door thickness
Pull tab large	E3-27-1	Add 2.4 (.09) to door thickness

Part Number

See table

Southco® Compression Latches

Vise Action Series, Flush Design

- Single-hole mount, large size
- Latch provides completely flush outer surface
- Designed for use in thicker panels such as wood
- Seven tool- or key-operated access styles

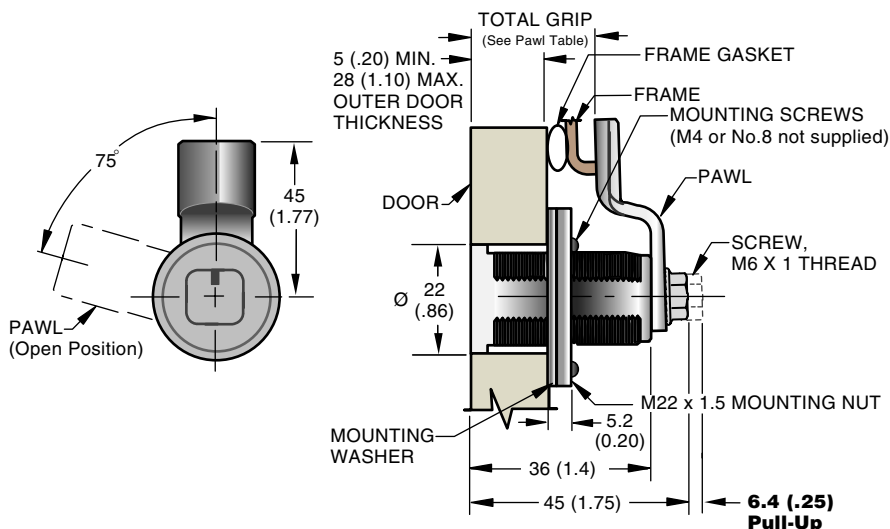

Pawl Detail

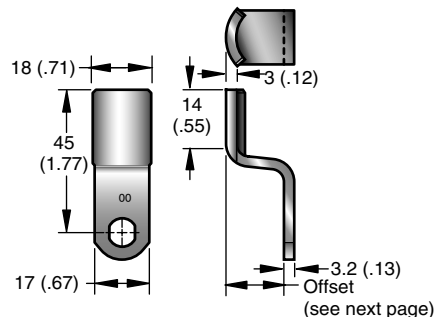

Mounting Washer

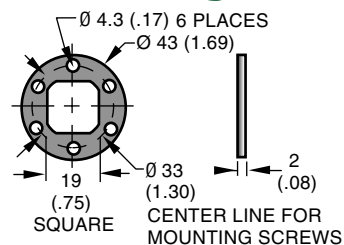

Mounting Nut

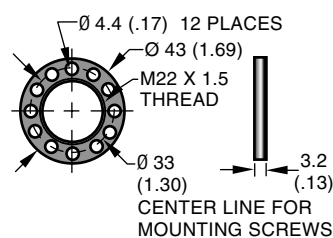

Key (Order Separately)

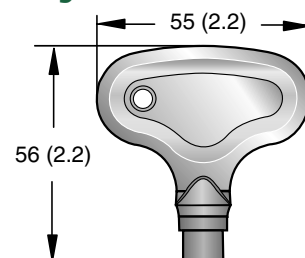

To determine the proper part number:

1. Choose a head style and finish (see table).
2. Determine the total grip by adding the following items together:
 - Outer door thickness
 - Compressed Frame Gasket
 - Frame thickness
3. Find your total grip in the pawl table. If your grip is between two choices, use the smaller one.
4. Use the 2 digit pawl type code that corresponds to your grip and outer door thickness to complete your latch assembly part number.

HEAD STYLE	8 mm Hex Recess	7 mm Triangle	7 mm Square	8 mm Square Driver	10 mm Hex	Railway Standard	8 mm Triangle
Bright Chrome	—	E3-143-XX1•	E3-144-XX1•	E3-1410-XX1•	E3-1418-XX1•	E3-1411-XX1•	E3-1420-XX1•
Black Powder Coated	E3-146-XX5	E3-143-XX5•	E3-144-XX5•	E3-1410-XX5•	E3-1418-XX5•	E3-1411-XX5•	E3-1420-XX5•
Satin Silver Polyester Powder Coated	E3-146-XX7	E3-143-XX7•	E3-144-XX7•	E3-1410-XX7•	E3-1418-XX7•	E3-1411-XX7•	E3-1420-XX7•
Keys	—	E3-3-1 •	E3-4-1 •	E3-8-1 •	10 mm (.375) Hex Recess (Not available from Southco)	RIC Standard (European Railway Standard) Not available from Southco	E3-7-1 •

Latches are individually packaged. For layer packaged latches (50 pieces minimum, sold in multiples of 50) add -13 to the part number. Example: E3-1410-XX1-13.

PAWL TYPE NUMBERS

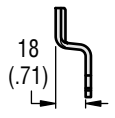
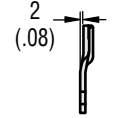
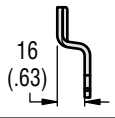
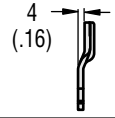
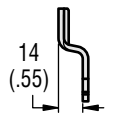
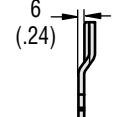
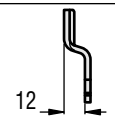
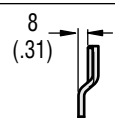
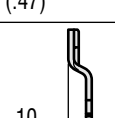
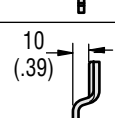
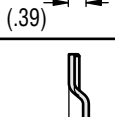
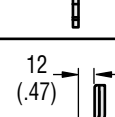
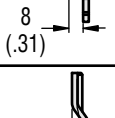
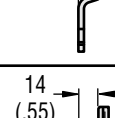
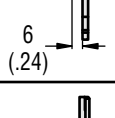
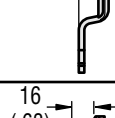
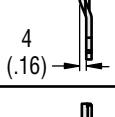
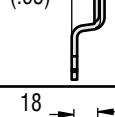
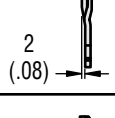
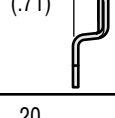
Pawl Type	TOTAL GRIP	Pawl Offset	Pawl Type	TOTAL GRIP	Pawl Offset
XX=00 •	19 (.75)		XX=10 •	39 (1.53)	
XX=01 •	21 (.83)		XX=11 •	41 (1.61)	
XX=02 •	23 (.91)		XX=12 •	43 (1.69)	
XX=03 •	25 (.98)		XX=13 •	45 (1.77)	
XX=04 •	27 (1.06)		XX=14	47 (1.85)	
XX=05 •	29 (1.14)		XX=15	49 (1.93)	
XX=06 •	31 (1.22)		XX=16	51 (2.01)	
XX=07 •	33 (1.30)		XX=17	53 (2.09)	
XX=08 •	35 (1.38)		XX=18	55 (2.17)	
XX=09 •	37 (1.46)		XX=19	57 (2.24)	



Material and Finish

HOUSING and CAP: Die-cast zinc, bright chrome plated or powder coated, see table. RETAINER and SPRING: 302 Stainless steel, natural. O-RING: Buna-N rubber, natural. CAM and SLEEVE: 1075 Case hardened steel, zinc immersion coating. SHAFT and SCREW: Low carbon steel, zinc plate, chromate plus sealer. PIN: 1008 Steel, zinc plated plus chromate dip. MOUNTING WASHER, MOUNTING NUT and PAWL: 1010 steel, zinc plate, chromate plus sealer.

Product Strength Guidelines

(To assist in your product selection; samples are available for your evaluation.)

Maximum static load: 300 N (79 lbs.)
Average ultimate load: 700 N (157 lbs.)

These loads apply to latch assemblies only. Retention to the panel is subject to user method of installation and material.

Panel Preparation

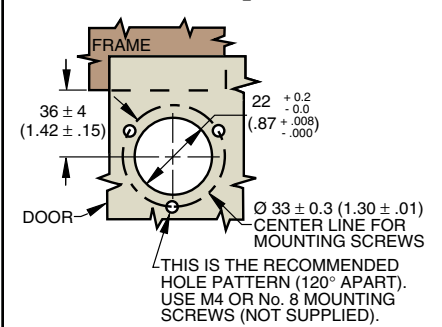

Installation

1. Insert the latch through the rear of the door. Place the mounting washer then the mounting nut onto the latch.
2. Adjust mounting nut so that the head of the latch is flush with the outside of the door. The holes in the washer and the nut must be aligned. The latch must be aligned to the latching position. Southco recommends using a minimum of three mounting screws in a pattern as shown above.
3. Place pawl on latch shaft and tighten pawl mounting screw while holding the pawl with a 17 (.67) wrench.

Recommended tightening torque for the Pawl Mounting Screw is 10 N•m (88.5 in-lbs).

millimeter (inch)
millimeter
(inch)

Dimensions without tolerances are for reference only.

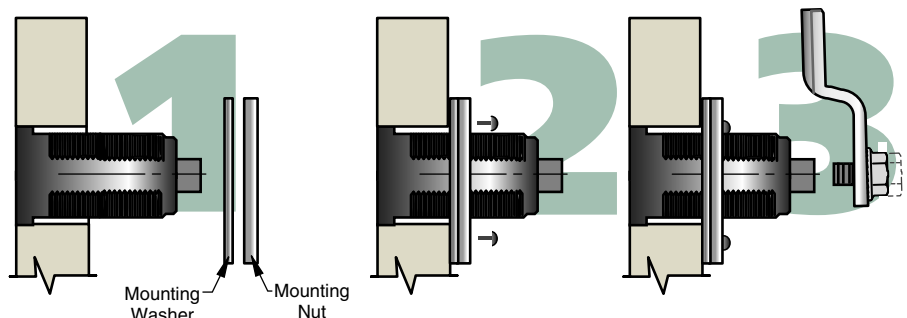

Southco® Compression Latches

Vise Action Series Knob Style

- Single-hole mount, large size
- Wider flange for mounting in non-metallic materials
- Knob provides quick, unrestricted access



Accessory for this latch. See page 36.

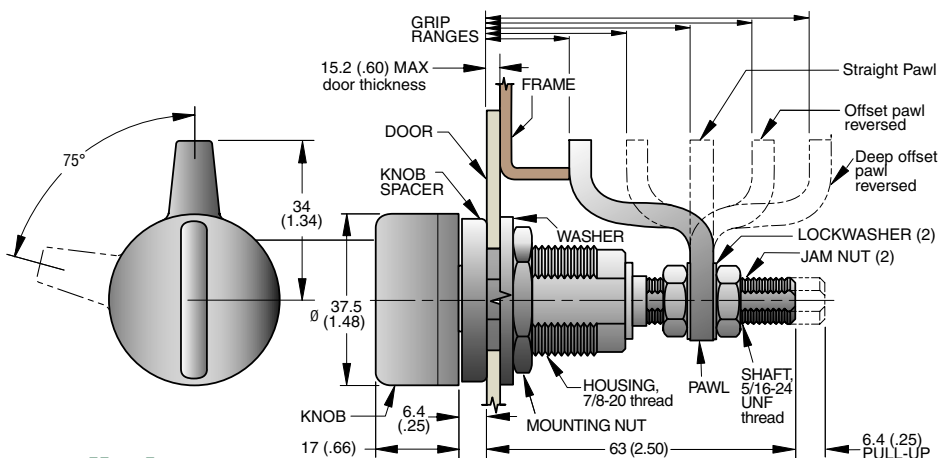

Installation

1.

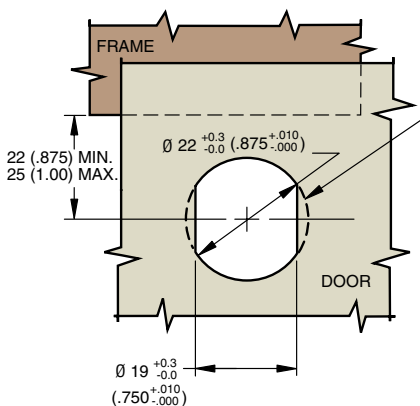

2.

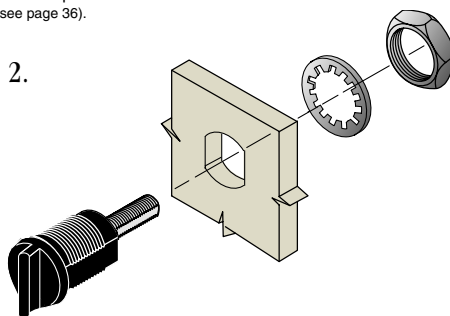

3.

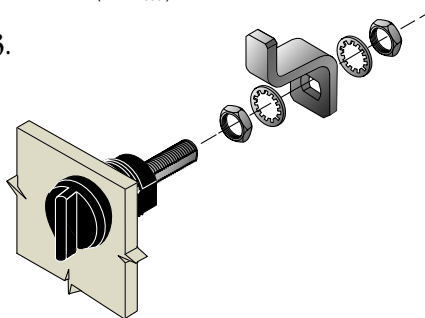

4. **To adjust grip:** Measure your grip. Open door. Position pawl on shaft to your grip measurement (with pawl in latched position). Tighten jam nuts hard against lock-washers and pawl using two wrenches.

For gasketed doors:

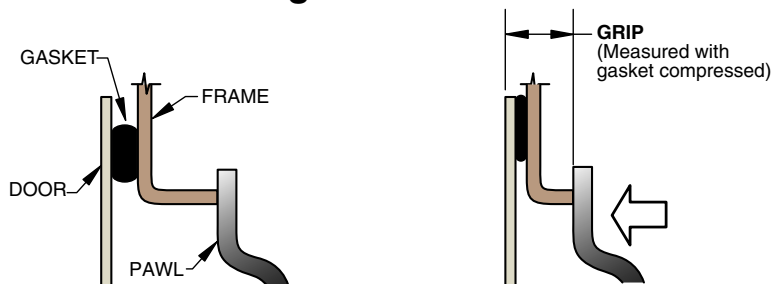

CAUTION: Set pawl position so that no more than 3.4 N•m (30 in.-lbs.) of torque is required to secure door.

Material and Finish

- HOUSING:** Die cast zinc, black powder coated.
SPRING: 302 Stainless steel, natural.
O-RING: Buna-N rubber, black.
PIN: 1008 Steel, zinc plated plus chromate dip.
WASHER and PAWL: 1010 Steel, zinc plate, chromate plus sealer.
CAM and SLEEVE: 1075 Case hardened steel, zinc immersion coating.
SHAFT: Low carbon steel, zinc plate, chromate plus sealer.
JAM NUTS: Steel, zinc plate, chromate plus sealer.
LOCKWASHERS: Spring steel, zinc plate, chromate plus sealer.
MOUNTING NUT: Brass, zinc plate, chromate plus sealer.
KNOB: Glass filled nylon, black.
KNOB SPACER: Nylon, black.
RETAINER: Polycarbonate, black.

GRIP RANGE		PART NUMBERS
MIN.	MAX.	
10 (.39)	27 (1.06)	E3-10-504-50 * •
24 (.94)	40 (1.57)	E3-10-505-50 * •
36 (1.42)	52.5 (2.06)	E3-10-506-50 ‡ •
49 (1.94)	65.5 (2.57)	E3-10-505-50 * •
63.5 (2.50)	79 (3.11)	E3-10-504-50 * •

Spur Washer listed on page, 36.

* The same pawl (curved forward or reversed) is supplied for both short and long grips.

‡ For intermediate grip, straight pawl is supplied.

Product Strength Guidelines

(To assist in your product selection; samples are available for your evaluation.)

Maximum static load: 445 N (100 lbs.)
 Average ultimate load: 890 N (200 lbs.)

millimeter (inch)
 millimeter
 (inch)

Dimensions without tolerances are for reference only.